

Type SRN Low Center of Gravity LM Guide with Caged Roller



NEW

A new, low-profile LM guide with caged roller has been developed. These types offer installation compatibility with the Type SNR LM guides for industrial machinery.

**SRN Series: SRN35C/45C/55C/35LC/45LC/55LC/65LC
SRN35R/45R/55R/35LR/45LR/55LR/65LR**

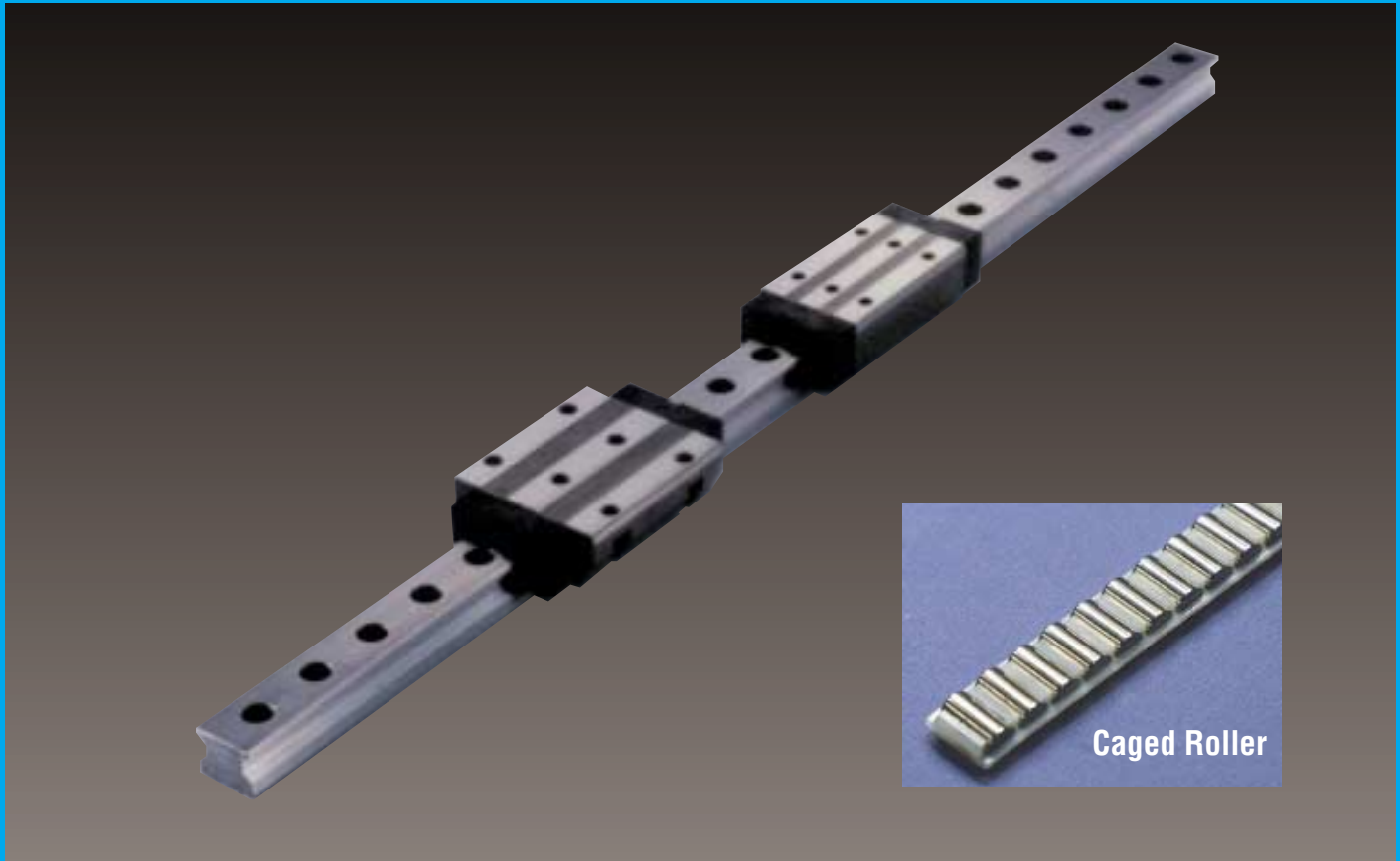

Features of the SRN Series

■ Low-Profile Design and High Rigidity (Type SNR Installation Compatibility)

The total height of the Type SRN is designed to be lower than that of the Type SRG LM guides. This makes these types suitable for more compact designs requiring high rigidity. Furthermore, these LM guides offer installation compatibility with the Type SNR ultra-heavy duty LM guides recommended for industrial machinery.

■ Improved Lubricating Properties by Preventing Skewing

Since the rollers circulate while uniformly aligned due to the caged roller, skewing is prevented when entering the load region of the block. Variations in rolling resistance have also been reduced allowing for stable and smooth movement.

■ Long-Term, Maintenance-Free Operation

The use of a caged roller eliminates friction between rollers and enables lubricating oil to be retained in the grease pockets between adjacent rollers. Since the required amount of lubricating oil is supplied to the curved contact surfaces of the spacers and rollers, long-term, maintenance-free operation is realized.

■ Ultra-High Rigidity

Rollers having a low degree of elastic deformation are used for the rolling elements, and the roller diameter and roller length have been optimized to realize extremely high rigidity. In addition, each row of rollers is arranged at a 45° contact angle so that the same rated load is applied in all directions (radial, reverse radial and lateral directions).

Effects of Caged Roller Technology+High Rigidity, Low Friction Rollers+Low-Profile Design

These low-profile, ultra-high rigidity LM guides employ caged rollers for low friction and smooth movement while also realizing long-term, maintenance-free operation.

Table of Dimensions of Model SRN-C

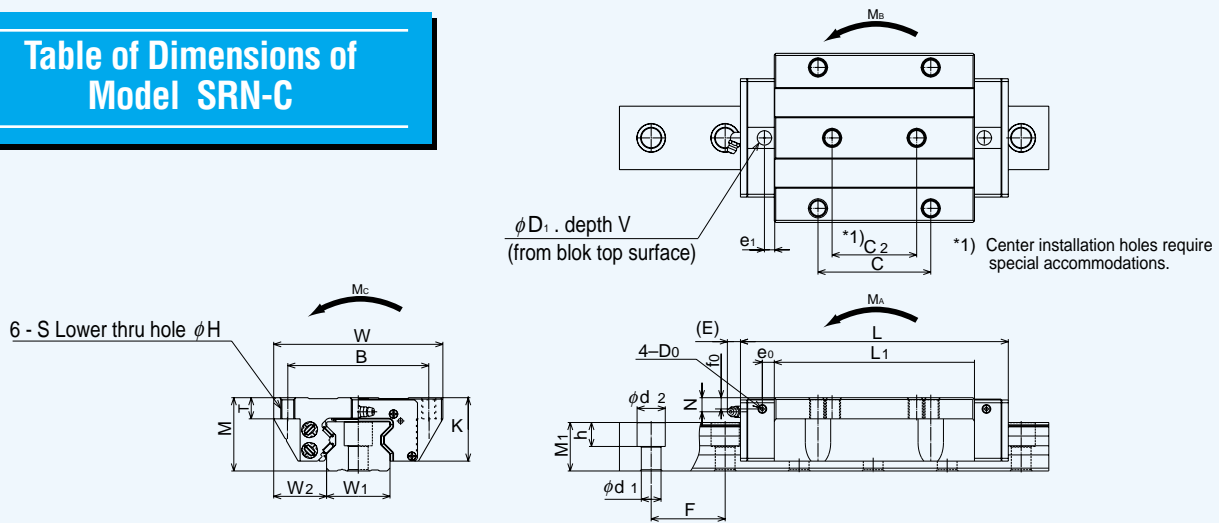

Unit : mm

Model number	Outline dimensions			LM block dimensions (mm)																
	Height M	Width W	Length L	B	C	C ₂	S	H	L ₁	T	K	N	E	e ₀	f ₀	D ₀	e ₁	D ₁	V	
SRN35C SRN35LC	44	100	125 155	82	62	52	M10	8.5	82.2 112.2	8	38	6.5	12	8	6.5	5.2	6	10.2	1.4	
SRN45C SRN45LC	52	120	155 190	100	80	60	M12	10.5	107 142	8	45	7	16	8.5	7	5.2	7	10.2	1.4	
SRN55C SRN55LC	63	140	185 235	116	95	70	M14	12.5	129 179.2	11	53	8	16	10	8	5.2	11	10.2	1.4	
SRN65LC	75	170	303	142	110	82	M16	14.5	229.8	20	65	14	16	9	11	5.2	10	10.2	1.4	

Model number	Grease nipple	LM rail dimensions (mm)					Basic load rating C		Static permissible moment			Mass	
		Width 0 W ₁ -0.05	Height W ₂	Pitch M ₁	Pitch F	d ₁ ×d ₂ ×h	kN	kN	M _A	M _B	M _C	LM block kg	LM rail kg/m
SRN35C SRN35LC	B-M6F	34	33	30	40	9×14×12	59.1 76	119 165	1.63 2.9	1.63 2.9	2.43 3.4	1.6 2.0	6.9
SRN45C SRN45LC	PT1/8	45	37.5	36	52.5	14×20×17	91.9 115	192 256	3.34 5.7	3.34 5.7	5.22 7.0	3.0 3.6	11.3
SRN55C SRN55LC	PT1/8	53	43.5	43	60	16×23×20	131 167	266 366	5.61 10.4	5.61 10.4	8.47 11.7	4.9 6.4	15.8
SRN65LC	PT1/8	63	53.5	49	75	18×26×22	278	599	21.8	21.8	22.8	12.7	21.3

Table of Dimensions of Model SRN-R

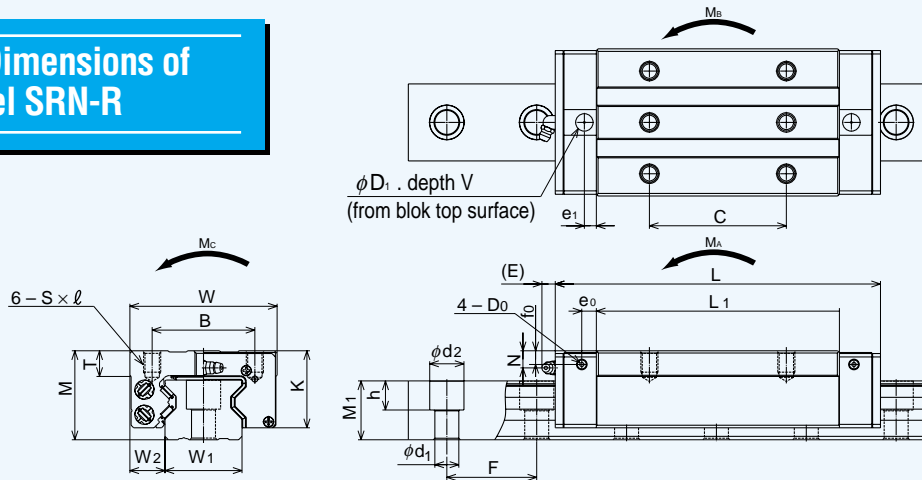

Unit : mm

Model number	Outline dimensions			LM block dimensions (mm)																
	Height M	Width W	Length L	B	C	S×L	L ₁	T	K	N	E	e ₀	f ₀	D ₀	e ₁	D ₁	V			
SRN35R SRN35LR	44	70	125 155	50	50	M8×9	82.2 112.2	8	38	6.5	12	8	6.5	5.2	6	10.2	1.4			
SRN45R SRN45LR	52	86	155 190	60	70 80	M10×11	107 142	8	45	7	16	8.5	7	5.2	7	10.2	1.4			
SRN55R SRN55LR	63	100	185 235	75	75 95	M12×13	129 179.2	11	53	8	16	10	8	5.2	11	10.2	1.4			
SRN65LR	75	126	303	76	120	M16×16	229.8	20	65	14	16	9	11	5.2	10	10.2	1.4			

Model number	Grease nipple	LM rail dimensions (mm)					Basic load rating C		Static permissible moment			Mass	
		Width 0 W ₁ -0.05	Height W ₂	Pitch M ₁	Pitch F	d ₁ ×d ₂ ×h	kN	kN	M _A	M _B	M _C	LM block kg	LM rail kg/m
SRN35R SRN35LR	B-M6F	34	18	30	40	9×14×12	59.1 76	119 165	1.63 2.9	1.63 2.9	2.43 3.4	1.1 1.4	6.9
SRN45R SRN45LR	PT1/8	45	20.5	36	52.5	14×20×17	91.9 115	192 256	3.34 5.7	3.34 5.7	5.22 7.0	1.9 2.5	11.3
SRN55R SRN55LR	PT1/8	53	23.5	43	60	16×23×20	131 167	266 366	5.61 10.4	5.61 10.4	8.47 11.7	3.2 4.5	15.8
SRN65LR	PT1/8	63	31.5	49	75	18×26×22	278	599	21.8	21.8	22.8	9.4	21.3