

THK



NEW

Small size shaft diameter $\phi 16 - \phi 32$

High-Speed Ball Screw with Caged Ball

Low noise, long-term maintenance-free operation

Low torque fluctuation

DN value: 130,000

SBN

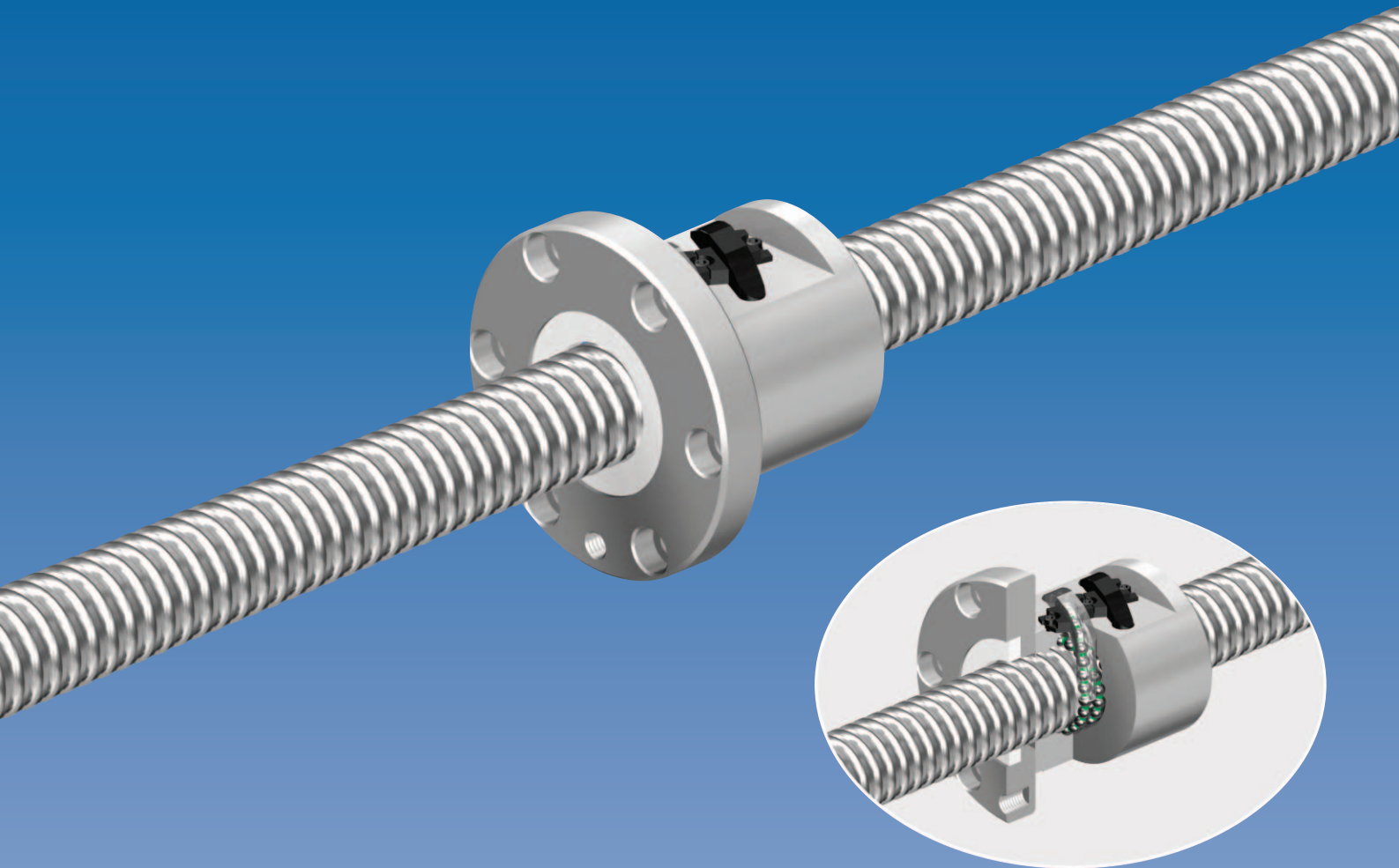

High-Speed Ball Screw with Caged ball technology

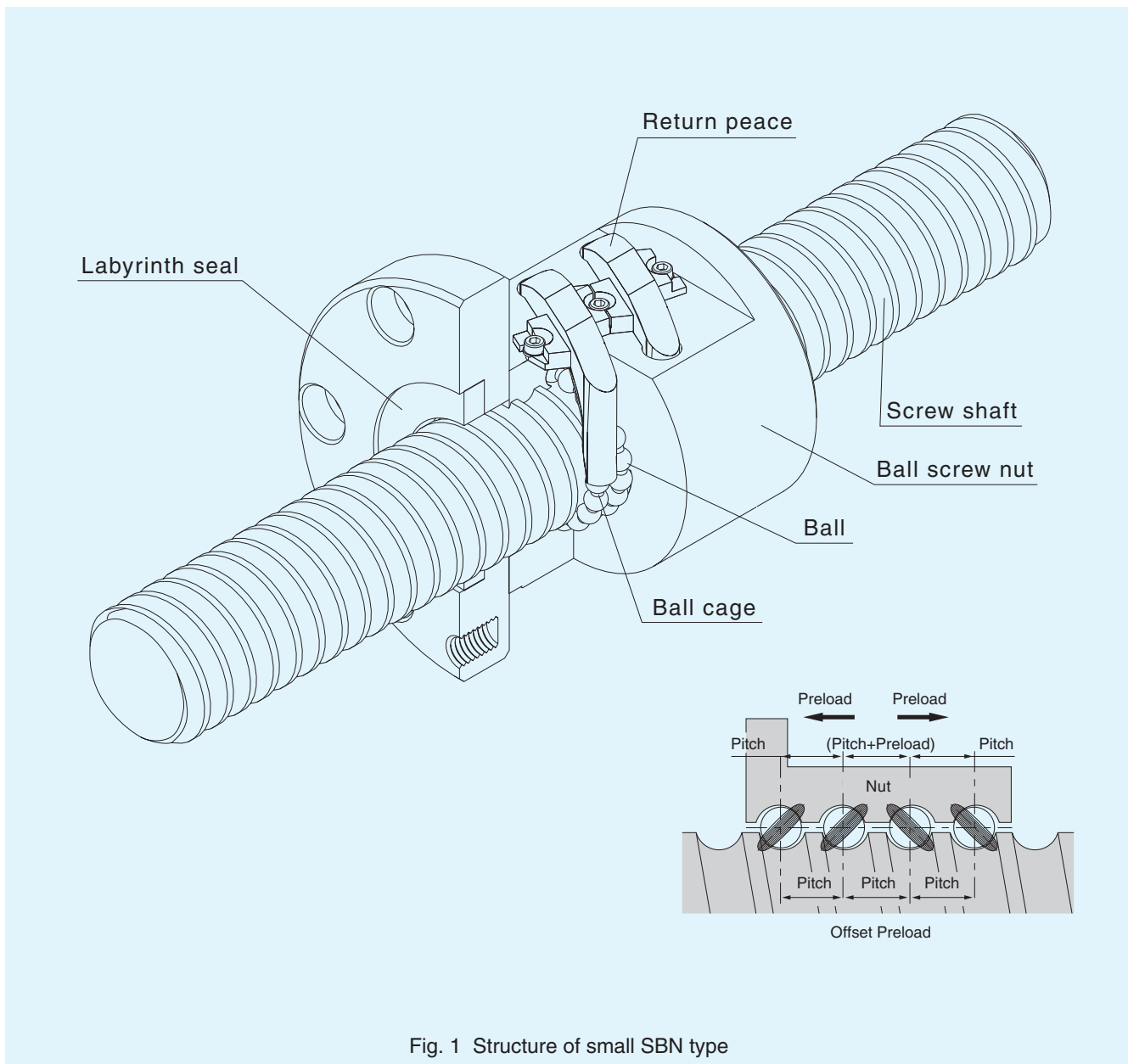

Fig. 1 Structure of small SBN type

Structure

A high-speed ball screw SBN is provided with caged ball technology in order to eliminate collisions and friction between balls and improve lubrication longevity. By doing this, low noise, excellent torque characteristics and long periods without maintenance were achieved. Increasing the strength of the circulating part by making an ideal cycle which can pick up the ball at a direction tangential with the return piece, permissible DN values of 130,000 were realized. (*: DN value = ball center diameter × number of rotations per minute)

Using an offset preload method that shifts the lead at the center of the nut allows for a shorter and more compact nut compared to the double nut used for the shim preload method.

Features

● Superbly High Speed

The SBN type return pipe is the ideal circulation method and does not have a lip so that the balls are picked up in a tangential direction and a flexible ball track can be held. Makes the use with DN value 130,000 possible.

● Smooth Motion

Use of a ball cage eliminates contact between balls (Fig. 3) and minimizes torque fluctuation, thus allowing smooth motion to be achieved.

● Long-Term Maintenance Free Operation

Increased grease retention through formation of grease pockets (Fig. 3) ensures long-term maintenance-free operation.

● Low Noise, acceptable Running Sound

Use of a ball cage placed to prevent each ball from contacting the adjacent ball eliminates collision noise between the balls (Fig. 3). In addition, the circulation structure where balls are picked up at the tangential direction (Fig. 2) also contributes to eliminating collision noise generated from circulating balls and decreases a noise level.

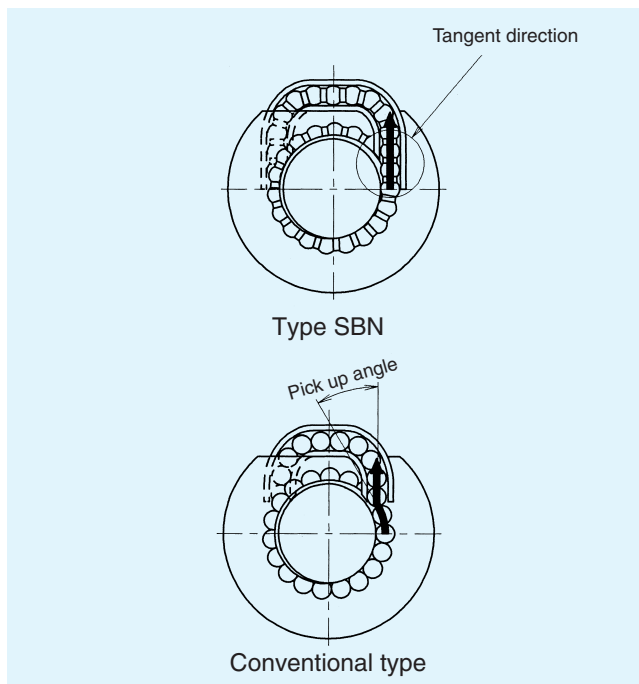

Fig. 2 Ball pick up structure

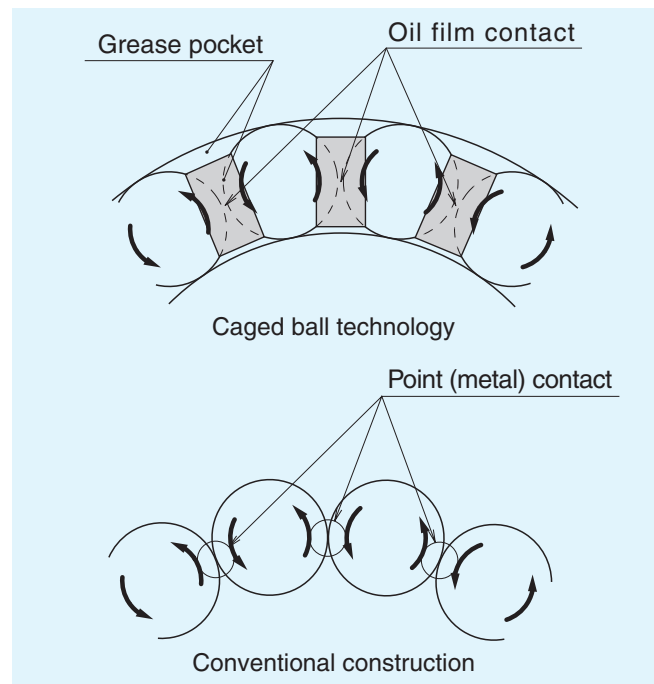

Fig. 3 Ball circulation structure

■ High Speed & Load Durability

Type SBN uses a new re-circulation tube and caged ball technology to achieve smooth circulation which maintains high speed and improved load durability.

High speed durability test (In the case of DN value 130,000)

Test condition

Category	Data
Model number	SBN2505-5
Rotational speed	5000min ⁻¹
Speed	25m / min
Stroke	400mm
Lubricant	AFF grease
Apply	2.5cm ³ (applied every 1000km)
Load	0.44kN
Acceleration	9.8m/s ² (1G)

Test result

No problems after 5000km travel

Load durability test

Test condition

Category	Data
Model number	SBN1604-5
Rotational speed	1500min ⁻¹
Speed	6m / min
Stroke	300mm
Lubricant	AFF grease
Apply	1.6cm ³ (Only the initial lubrication)
Load	2.12kN
Acceleration	4.9m/s ² (0.5G)

Test result

Operated for 2.5 times estimated life span without a problem (Currently in operation)

■ Smooth Rotation

Type SBN uses caged ball technology, so it is possible to get smoother rotation compared to conventional types.

Category	Data
Model Number	SBN2505-5
Rotational speed	60min ⁻¹

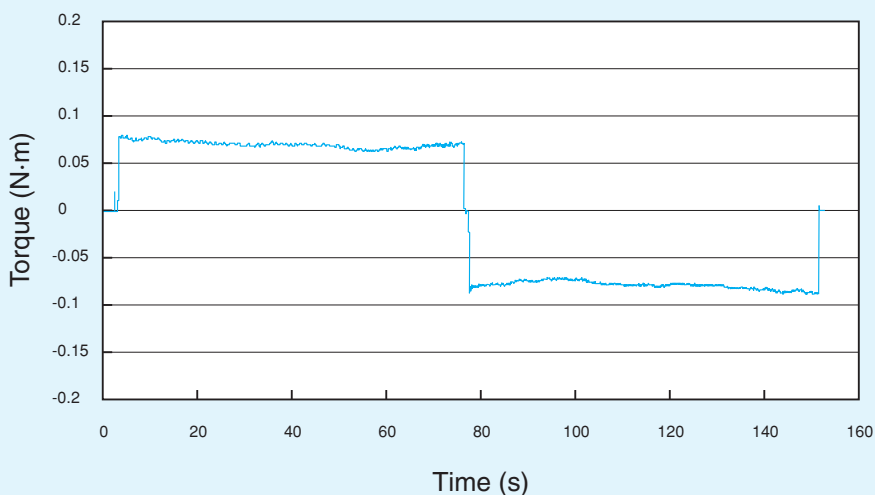

Low Noise

Type SBN maintains quiet operation under high-speed rotation by adopting caged ball technology that eliminates collisions of adjacent metal balls.

Item	Description
Lubricator	AFF grease
Measure	1m

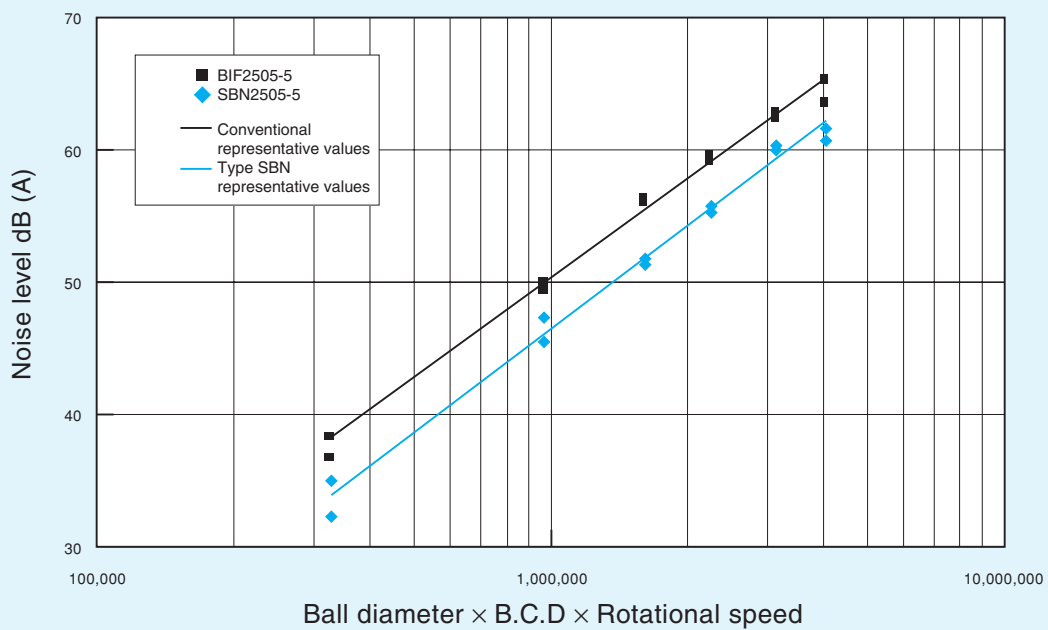
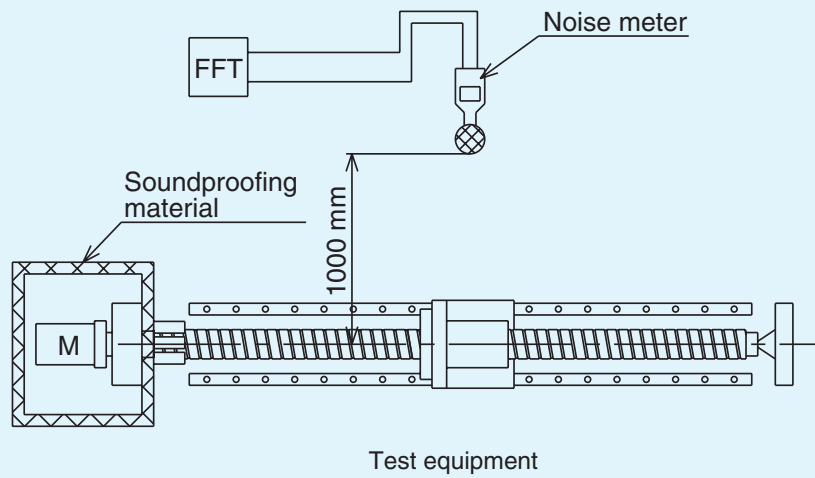

Accuracy Standard

High-Speed Ball Screw with Caged Ball is manufactured with accuracy compliant with JIS B1192 (precision Ball Screw). This model can be manufactured with up to the maximum accuracy of C0 grade. In terms of lead accuracy measurement, the lead accuracy is assured with a laser measurement machine, whose reliability is proven. For details of the standard values, see the General Catalog.

Static Safety Factor

Basic Static Load Rating C_{0a}

If a Ball Screw receives an excessive load or a large impact load while it is stationary or in motion, local permanent deformation occurs between the raceway and the steel ball. If the permanent deformation exceeds a certain limit, it will prevent smooth motion.

It is established that in general, if the permanent deformation is approximately 0.0001 times the steel ball diameter, there is no problem in operation at all. The load applied here is called a basic static load rating C_{0a} . Depending on the service conditions, it is necessary to consider a static safety factor in the axial direction as indicated in table 1.

Static Safety Factor

$$f_s \leq \frac{C_{0a}}{F_a}$$

f_s : Static safety factor (table 1)

C_{0a} : Basic static load rating [kN]

F_a : Axial load [kN]

Table 1 Static Safety Factor

Loading conditions	Machine used	Lower limit of f_s
General industry machine	Without vibration/impact	1.0 to 1.3
	With vibration/impact	2.0 to 3.0
Machine tool	Without vibration/impact	1.0 to 1.5
	With vibration/impact	2.5 to 7.0

Rated Life and Service Life Time

Basic Dynamic Load Rating C_a

The factor basic dynamic load rating C_a is used to calculate the service life of a Ball Screw when the ball screw nut operates under a load.

Basic dynamic load rating C_a refers to an axial load under which the rated load on 90% of a group of identical Ball Screw units independently operating is 10^6 rev (1 million revolutions).

Rated Life

The service life of a Ball Screw is obtained from the following equation using the basic dynamic load rating and the axial load.

$$L = \left(\frac{C_a}{f_w \cdot F_a} \right)^3 \times 10^6$$

L : Rated life [rev]

C_a : Basic dynamic load rating [N]

F_a : Axial load [N]

f_w : Load factor (table 2)

Table 2 Load Factor

Vibrations/impact	Speed (V)	f_w
Faint	Very low $V \leq 0.25$ m/s	1.0 to 1.2
Weak	Low $0.25 \leq V \leq 1.0$ m/s	1.2 to 1.5
Medium	Moderate $1.0 \leq V \leq 2.0$ m/s	1.5 to 2.0
Strong	High 2.0 m/s < V	2.0 to 3.5

Service Life Time

When the rated life L has been obtained, the service life time is calculated from the following equation if the stroke length and the number of reciprocations are constant.

$$L_h = \frac{L \times \ell}{2 \times \ell_s \times n_1 \times 60}$$

L_h : Service life time [h]

ℓ_s : Stroke length [min]

n_1 : Revolutions per minute [min^{-1}]

ℓ : Lead [min]

MEMO

Dimensional Table for Model SBN

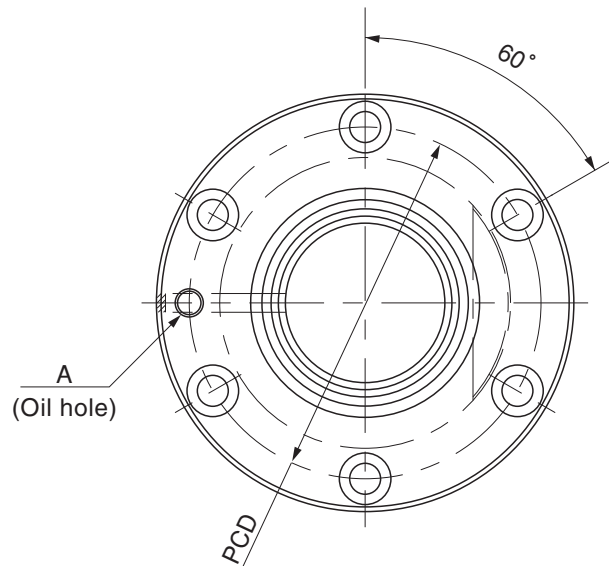

Model No.	Screw shaft outer diameter d	Lead Ph	No. of loaded circuits Rows × turns	Ball center-to- center diameter dp	Thread minor diameter dc	Basic load rating		Rigidity K [N/μm]
						Ca [kN]	Coa [kN]	
SBN1604-5	16	4	1 × 2.5	16.5	13.8	5.3	8	281
SBN1605-5	16	5	1 × 2.5	16.75	13.2	9.2	12.9	309
SBN2004-5	20	4	1 × 2.5	20.5	17.8	5.9	10.1	335
SBN2005-5	20	5	1 × 2.5	20.75	17.2	10.3	16.2	370
SBN2504-5	25	4	1 × 2.5	25.5	22.8	6.4	12.7	400
SBN2505-5	25	5	1 × 2.5	25.75	22.2	11.3	20.3	442
SBN2506-5	25	6	1 × 2.5	26	21.4	15.4	25.4	457
SBN2805-5	28	5	1 × 2.5	28.75	25.2	11.8	22.8	483
SBN2806-5	28	6	1 × 2.5	29	24.4	16.2	28.5	499
SBN3205-5	32	5	1 × 2.5	32.75	29.2	12.6	26.1	536
SBN3206-5	32	6	1 × 2.5	33	28.4	17.2	32.7	555

Example of Model Number Coding

SBN1604-5 QZ RR G0 + 1200L C5

① ② ③ ④ ⑤ ⑥

- ① Model number
- ② With QZ Lubricator (without QZ Lubricator: no symbol)
- ③ Seal symbol RR: labyrinth seal on both ends
WW: wiper ring on both ends
- ④ Axial clearance symbol (All SBN from is G0)
- ⑤ Overall screw shaft length (in mm)
- ⑥ Accuracy symbol

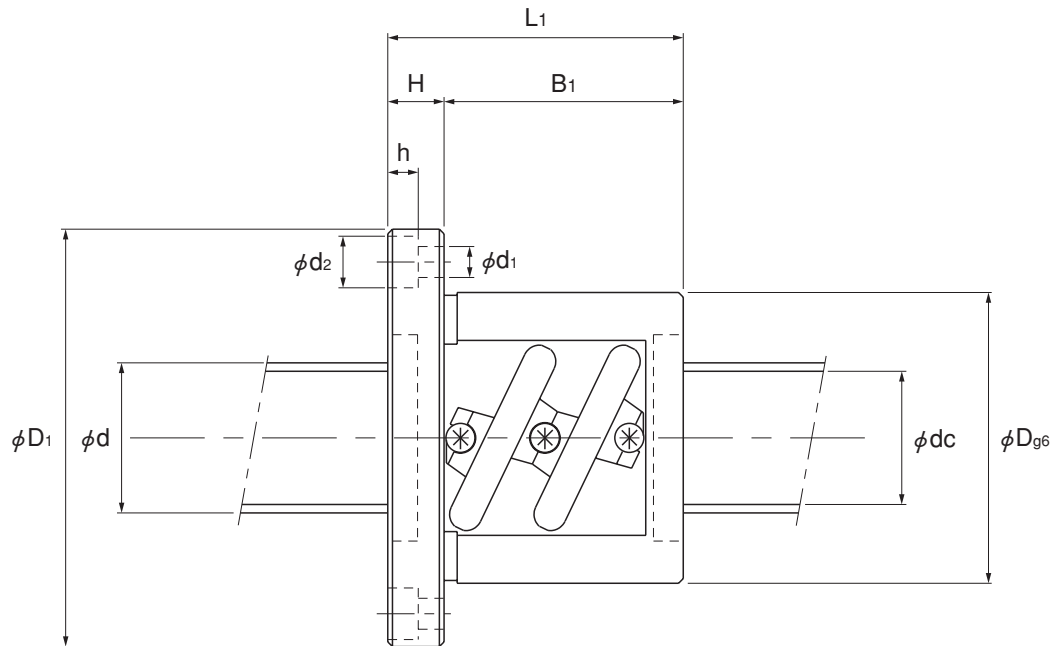

Unit: mm

Outer diameter D	Flange diameter D ₁	Overall length L ₁	Nut dimensions				Greasing hole A	Screw shaft inertial moment/mm [kg·cm ² /mm]	Nut mass [kg]	Shaft mass [kg/m]
			H	B ₁	PCD	d ₁ × d ₂ × h				
36	59	53	11	42	47	5.5×9.5×5.5	M6×1	5.05×10 ⁻⁴	0.42	1.35
40	60	56	10	46	50	4.5×8×4.5	M6×1	5.05×10 ⁻⁴	0.50	1.25
40	63	53	11	42	51	5.5×9.5×5.5	M6×1	1.23×10 ⁻³	0.48	2.18
44	67	56	11	45	55	5.5×9.5×5.5	M6×1	1.23×10 ⁻³	0.61	2.06
46	69	48	11	37	57	5.5×9.5×5.5	M6×1	3.01×10 ⁻³	0.55	3.5
50	73	55	11	44	61	5.5×9.5×5.5	M6×1	3.01×10 ⁻³	0.72	3.35
53	76	62	11	51	64	5.5×9.5×5.5	M6×1	3.01×10 ⁻³	0.90	3.19
55	85	59	12	47	69	6.6×11×6.5	M6×1	4.74×10 ⁻³	0.98	4.27
59	89	63	12	51	73	6.6×11×6.5	M6×1	4.74×10 ⁻³	1.19	4.33
58	85	56	12	44	71	6.6×11×6.5	M6×1	8.08×10 ⁻³	0.96	5.67
62	89	63	12	51	75	6.6×11×6.5	M6×1	8.08×10 ⁻³	1.22	6.31

Note: The rigidity values in the table represent spring constants each obtained from the load and the elastic displacement when providing a preload 10% of the basic dynamic load rating (Ca) and applying an axial load three times greater than the preload. These values do not include the rigidity of the components related to mounting the ball screw nut. Therefore, it is normally appropriate to regard roughly 80% of the value in the table as the actual value.

If the applied preload (Fa0) is not 0.1 Ca, the rigidity value (KN) is obtained from the following equation.

$$K_N = K \left(\frac{F_{a0}}{0.1 C_a} \right)^{\frac{1}{3}} \quad K: \text{Rigidity value in the dimensional table.}$$

●Note

With model SBN, the screw shaft cannot be threaded at both ends. If designing SBN with threaded ends, contact THK.

Options

Type SBN can be equipped with lubricator QZ, which is a ball screw lubricator system containing a high-density fiber net with high oil content for longer maintenance-free periods, as well as a contact seal and wiper ring offering superb contamination protection capabilities for ball screws.

■ Lubricator QZ

Lubricator QZ is a new lubricating system that can supply an appropriate amount of lubricating oil to the parts requiring it.

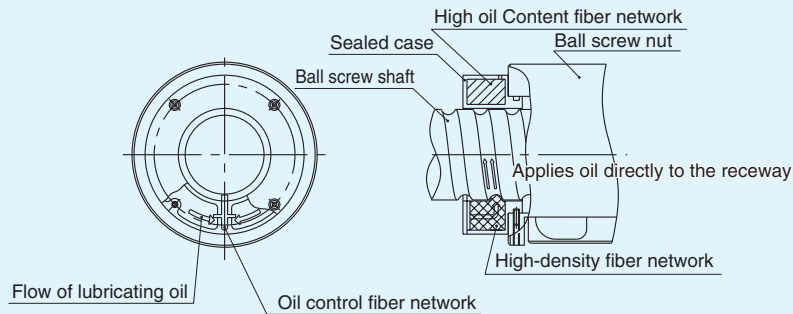

<Features>

● Enables longer maintenance-free intervals

Normally, a small amount of oil is lost from ball screws during operation. By adding the lubricator QZ, oil lost over long periods is automatically replaced, greatly lengthening maintenance-free intervals.

● Lubricator QZ is environmentally conscious

Because lubricator QZ uses a high-density fiber net to supply the appropriate amount of oil to the appropriate positions, there is no excess oil, making it an environmentally conscious design.

● The best oil for each application can be used

For further details contact THK.

(Applicable lubricating oil standard = ISO VG220)

■ Wiper Ring

The wiper ring adopts a specialized resin with friction resistant properties that forms an elastic contact on the outer shaft and screw grooves, thus protecting the slits in 8 places from contamination and preventing foreign matter from penetrating into the ball screw nut.

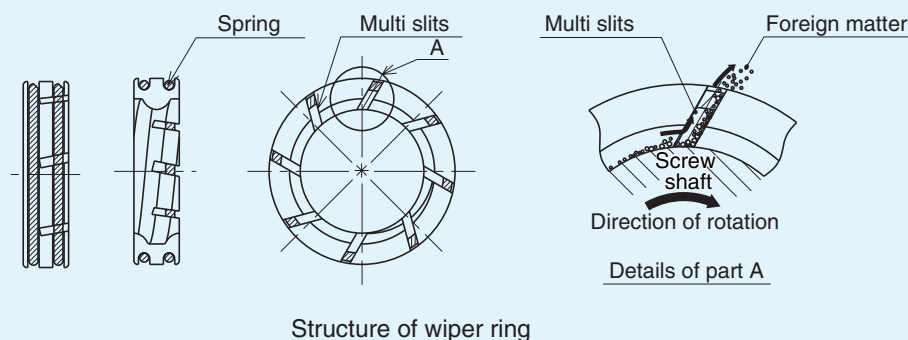

<Features>

- Prevents foreign matter penetrating the ball screw nut.
- Suppresses heat generation by fixed-pressure contact with screw shaft.
- Excellent resistance to friction, collision and chemicals.
- Incorporating lubricator QZ makes long-term maintenance-free operation a reality, even in adverse environments.

The Ball Screw Nut Dimensions with the Wiper Ring (WW) and QZ Lubricator (QZ) Attached

● WW Attached

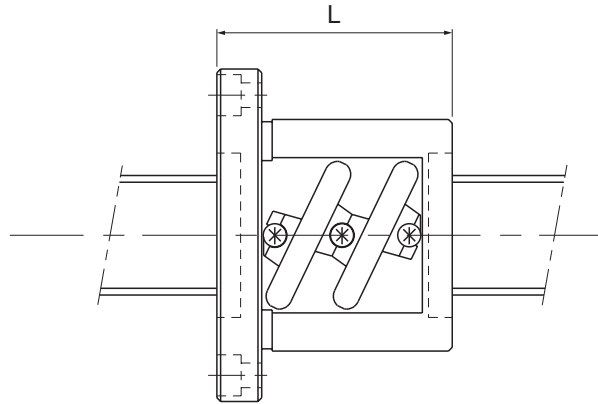

● QZWW (QZRR)

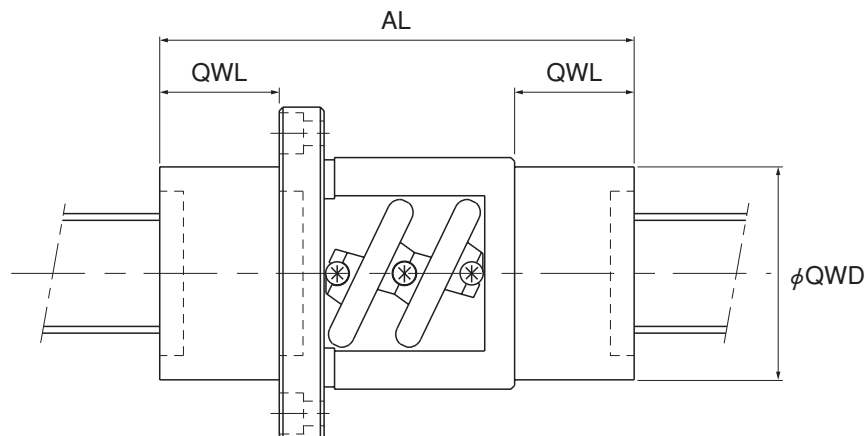

Unit: mm

Model No.	*Dimensions including WW	Dimensions including QZWW		
	Overall length L	Length QWL	Outer diameter QWD	Overall length AL
SBN1604-5	53	29	31	111
SBN1605-5	56	29	31	114
SBN2004-5	53	27.5	39	108
SBN2005-5	56	27.5	43	111
SBN2504-5	48	32.5	45	113
SBN2505-5	55	32.5	45	120
SBN2506-5	62	33	45	128
SBN2805-5	59	22	54	103
SBN2806-5	63	22	54	107
SBN3205-5	56	32	57	120
SBN3206-5	63	32	57	127

*1 Full length dimensions with WW are normal full length and of the same size methods.

*2 Being accompanied is dimensions same as QZWW a QZ+ labyrinth seal.

THK High-Speed Ball Screw with Caged Ball Model SBN

Precautions on Use

● Handling

- Disassembling components may cause dust to enter the system or degrade mounting accuracy of parts. Do not disassemble the product.
- Tilting the screw shaft and the ball screw nut may cause them to fall by their self-weights.
- Dropping or hitting the Ball Screw may damage the ball circulation section, which may cause functional loss. Giving an impact to the product could also cause damage to its function even if the product looks intact.

● Lubrication

- Thoroughly remove anti-corrosion oil and feed lubricant before using the product.
- Do not mix lubricants of different physical properties.
- In locations exposed to constant vibrations or in special environments such as clean rooms, vacuum and low/high temperature, normal lubricants may not be used. Contact THK for details.
- When planning to use a special lubricant, contact THK before using it.
- Lubrication interval varies according to the service conditions. Contact THK for details.

● Precautions on Use

- Do not remove the ball screw nut from the screw shaft. Doing so may cause the balls or the ball cage to fall off.
- Entrance of foreign matter to the ball screw nut may cause damage to the ball circulating path or functional loss. Prevent foreign matter, such as dust or cutting chips, from entering the system.
- If foreign matter adheres to the product, replenish the lubricant after cleaning the product. For the type of cleaning liquid, contact THK.
- Use a cover or the like to prevent the coolant from entering the ball screw nut.
- Do not use the product at temperature of 80°C or higher. When desiring to use the system at temperature of 80°C or higher, contact THK in advance.
- If using the product with vertical mount, the ball screw nut may fall by its self-weight. Attach a mechanism to prevent it from falling.
- Using the product at speed exceeding the permissible rotation speed may cause breakage of a component or accident. Be sure to use the product within the specification range designated by THK.
- Forcibly driving in the screw shaft or the ball screw nut may cause an indentation on the raceway. Use care when mounting components.
- If an offset or skewing occurs with the ball screw shaft support and the ball screw nut, it may substantially shorten the service life. Pay much attention to components to be mounted and to the mounting accuracy.
- When using the product in locations exposed to constant vibrations or in special environments such as clean rooms, vacuum and low/high temperature, contact THK in advance.
- Letting the ball screw nut overrun will cause balls to fall off or the ball-circulating component to be damaged. Be sure not to let it overrun.

● Storage

When storing the Ball Screw, enclose it in a package designated by THK and store it in a horizontal orientation while avoiding high temperature, low temperature and high humidity.

● “LM Guide,” “Caged Ball,” and “” are registered trademarks of THK CO., LTD.

- The photo may differ slightly in appearance from the actual product.
 - The appearance and specifications of the product are subject to change without notice. Contact THK before placing an order.
 - Although great care has been taken in the production of this catalog, THK will not take any responsibility for damage resulting from typographical errors or omissions.
 - For the export of our products or technologies and for the sale for exports, THK in principle complies with the foreign exchange law and the Foreign Exchange and Foreign Trade Control Law as well as other relevant laws.
- For export of THK products as single items, contact THK in advance.

All rights reserved

THK CO., LTD.

HEAD OFFICE 3-11-6, NISHI-GOTANDA, SHINAGAWA-KU, TOKYO 141-8503 JAPAN
INTERNATIONAL SALES DEPARTMENT PHONE:+81-3-5434-0351 FAX:+81-3-5434-0353
Global site : <http://www.thk.com/>

NORTH AMERICA

THK America, Inc.
● HEADQUARTERS
Phone:+1-847-310-1111 Fax:+1-847-310-1271
● CHICAGO OFFICE
Phone:+1-847-310-1111 Fax:+1-847-310-1182
● NEW YORK OFFICE
Phone:+1-845-369-4035 Fax:+1-845-369-4909
● ATLANTA OFFICE
Phone:+1-770-840-7990 Fax:+1-770-840-7897
● LOS ANGELES OFFICE
Phone:+1-949-955-3145 Fax:+1-949-955-3149
● SAN FRANCISCO OFFICE
Phone:+1-925-455-8948 Fax:+1-925-455-8965
● BOSTON OFFICE
Phone:+1-781-575-1151 Fax:+1-781-575-9295
● DETROIT OFFICE
Phone:+1-248-858-9330 Fax:+1-248-858-9455
● TORONTO OFFICE
Phone:+1-905-820-7800 Fax:+1-905-820-7811

SOUTH AMERICA

THK Brasil LTDA
Phone:+55-11-3767-0100 Fax:+55-11-3767-0101

EUROPE

THK GmbH
● EUROPEAN HEADQUARTERS
Phone:+49-2102-7425-0 Fax:+49-2102-7425-217

● DÜSSELDORF OFFICE

Phone:+49-2102-7425-0 Fax:+49-2102-7425-299
● FRANKFURT OFFICE
Phone:+49-2102-7425-650 Fax:+49-2102-7425-699
● STUTTGART OFFICE
Phone:+49-7150-9199-0 Fax:+49-7150-9199-888
● MÜNCHEN OFFICE
Phone:+49-8937-0616-0 Fax:+49-8937-0616-26
● U.K. OFFICE
Phone:+44-1908-30-3050 Fax:+44-1908-30-3070
● ITALY MILANO OFFICE
Phone:+39-039-284-2079 Fax:+39-039-284-2527
● ITALY BOLOGNA OFFICE
Phone:+39-051-641-2211 Fax:+39-051-641-2230
● SWEDEN OFFICE
Phone:+46-8-445-7630 Fax:+46-8-445-7639
● AUSTRIA OFFICE
Phone:+43-7229-51400 Fax:+43-7229-51400-79
● SPAIN OFFICE
Phone:+34-93-652-5740 Fax:+34-93-652-5746
● TURKEY OFFICE
Phone:+90-216-362-4050 Fax:+90-216-569-7150
THK France S.A.S.
Phone:+33-4-3749-1400 Fax:+33-4-3749-1401

CHINA

THK (CHINA) CO.,LTD.
● HEADQUARTERS
Phone:+86-411-8733-7111 Fax:+86-411-8733-7000

● SHANGHAI OFFICE

Phone:+86-21-6219-3000 Fax:+86-21-6219-9890
● BEIJING OFFICE
Phone:+86-10-8441-7277 Fax:+86-10-6590-3557
● CHENGDU OFFICE
Phone:+86-28-8526-8025 Fax:+86-28-8525-6357
● GUANGZHOU OFFICE
Phone:+86-20-8333-9770 Fax:+86-20-8333-9726
THK (SHANGHAI) CO.,LTD.
Phone:+86-21-6275-5280 Fax:+86-21-6219-9890

TAIWAN

THK TAIWAN CO.,LTD.
● TAIPEI HEAD OFFICE
Phone:+886-2-2888-3818 Fax:+886-2-2888-3819
● TAICHUNG OFFICE
Phone:+886-4-2359-1505 Fax:+886-4-2359-1506
● TAINAN OFFICE
Phone:+886-6-289-7668 Fax:+886-6-289-7669

KOREA

SEOUL REPRESENTATIVE OFFICE
Phone:+82-2-3468-4351 Fax:+82-2-3468-4353

SINGAPORE

THK LM SYSTEM Pte. Ltd.
Phone:+65-6884-5500 Fax:+65-6884-5550

INDIA

BANGALORE REPRESENTATIVE OFFICE
Phone:+91-80-2330-1524 Fax:+91-80-2314-8226