

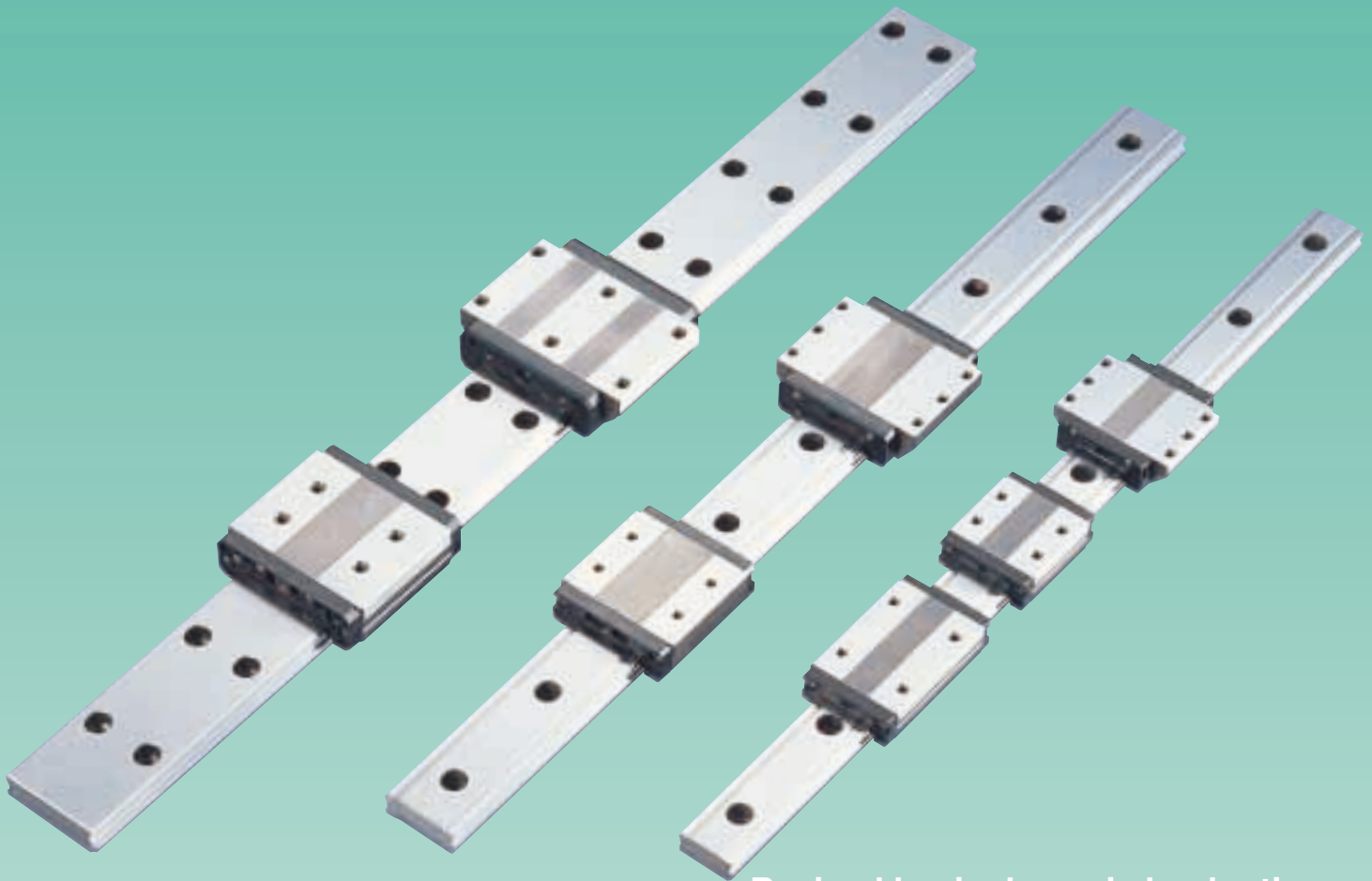

Advantages of Caged Ball™ Technology

High speed performance
Low noise design, Long service life,
Long-term maintenance-free operation
Reduction in rolling resistance variation

SHW



Revised basic dynamic load ratings

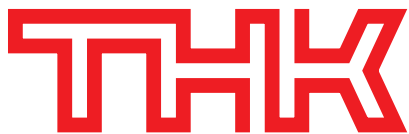

The ideal extra-wide construction with a low center of gravity for use with single rails
LM Guide with Caged Ball™ Technology

SHW

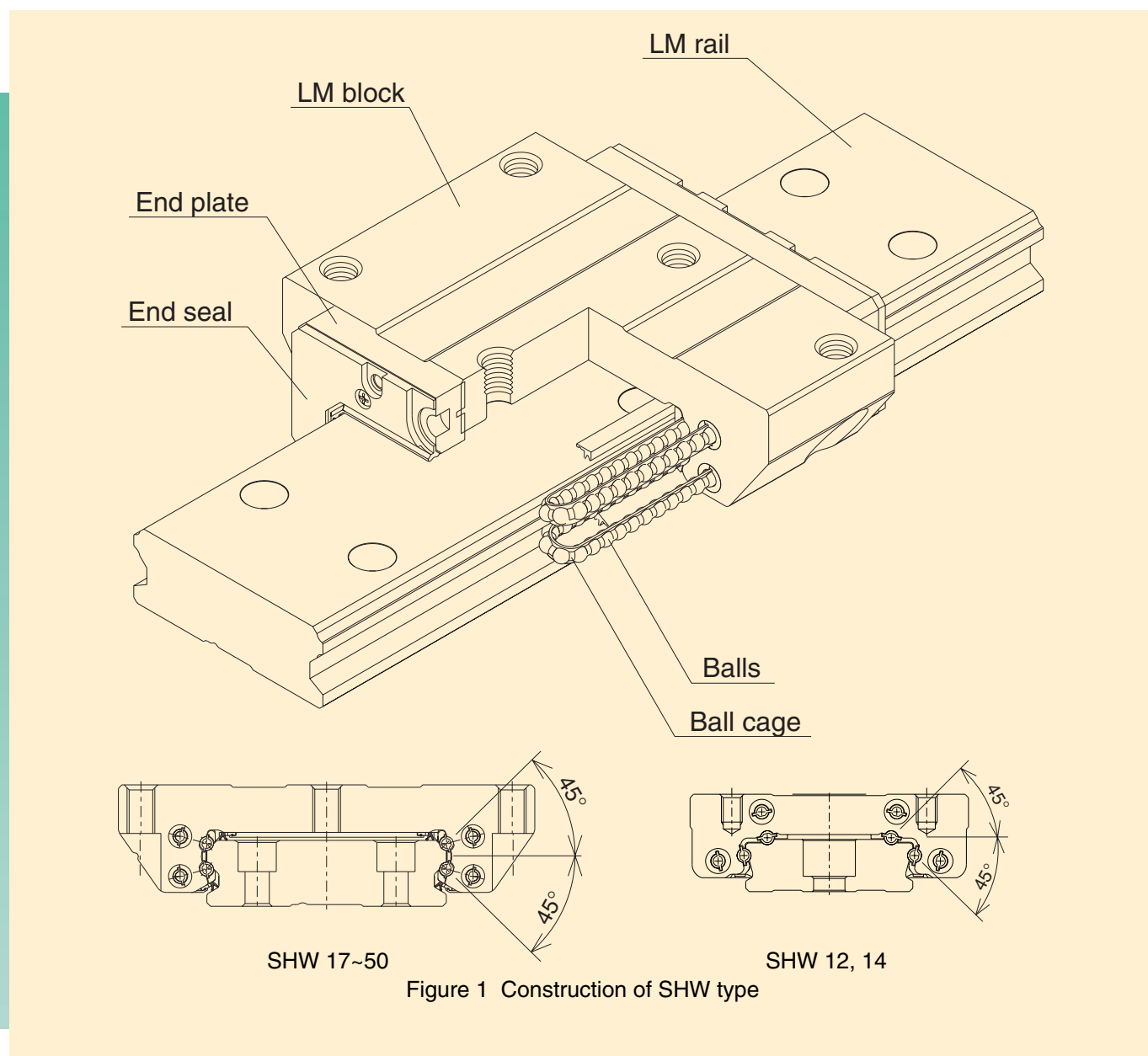

Extra-wide, high-rigidity LM Guide, incorporating Caged Ball™ Technology, has been developed to provide users with high speed, low-noise, long-term, maintenance-free service.

Friction Between Balls

■ Linear motion (LM) guide

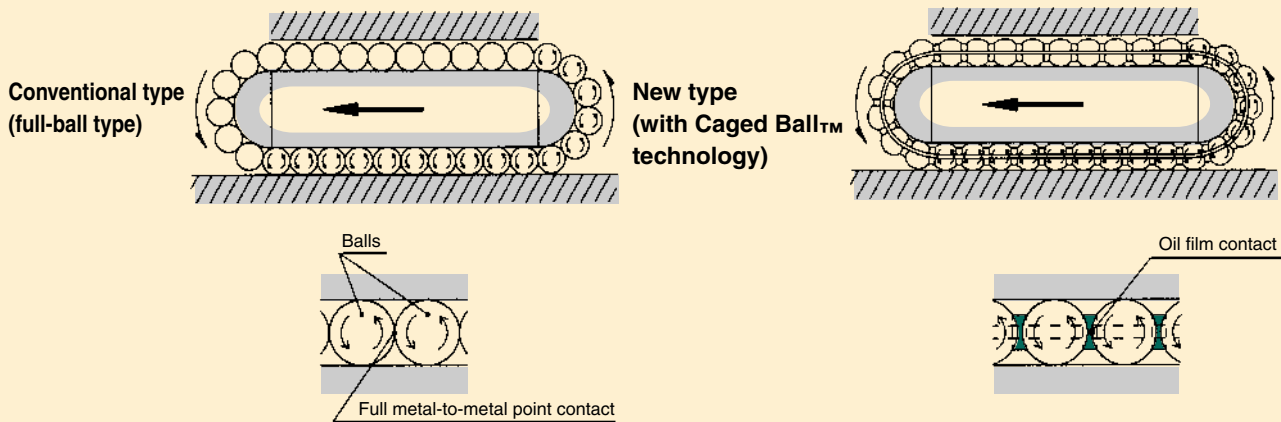

■ Rotary ball bearing

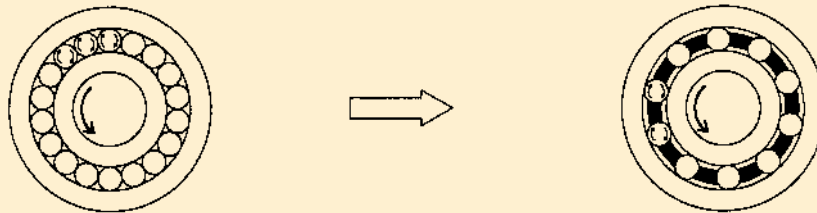

In the first stage of development (full-ball type)

- Because adjacent balls fully touch each other, contact stress is high and friction occurs due to breakdown of the oil film.
- The effective life of the bearing becomes shorter.

Present bearing (with Caged Ball™ technology)

- The absence of friction between adjacent balls extends the effective life of the bearing.
- Heat generation during high-speed rotation is limited due to the absence of friction between the balls.
- There is no noise of balls colliding since the balls do not touch each other.
- The balls move smoothly since they are spaced equally around the bearing.
- The lubricating oil is retained in the bearing, providing excellent lubrication and prolonging the life of the bearing.

The first rotary bearings developed did not have ball cages. They were noisy, could not operate at high speeds and had a short working life.

Twenty years later, rotary bearings with ball cages were developed, providing bearings that were quiet, could operate at high speeds and had a long service life despite the fact that they used fewer ball bearings. This constituted a major turning point in the development of rotary bearings. The history of needle bearings also testifies to the huge improvement in bearing quality that resulted from the introduction of ball cages.

Where a ball cage is not used, there is direct metal-to-metal contact between the ball bearings. At this contact point, the surfaces are rotating in opposite directions, resulting in a contact speed that is twice the bearing rotation rate. This in turn results in high levels of friction and noise and a short operating life.

Normally, the oil film breaks down at a surface pressure of 3 kg/mm². Where there is direct contact between the balls, the pressure between the ball surfaces is unlimited, causing the oil film to break down and resulting in metal-to-metal contact.

By contrast, balls in a retaining cage contact the cage over a large surface area. This prevents breakdown of the oil film and provides for quieter operation, higher rotation speeds and a longer operating life.

At THK, we utilized our many years of experience along with innovative manufacturing techniques to develop the new Caged Ball™ Technology, and we have built this technology into the new generation of smooth-running LM guides. The main features of the new LM guides are as follows.

Low noise

Kept separate in the ball cage, the balls do not touch each other, so noise levels are low with none of the metallic clattering you hear from full-ball type bearings.

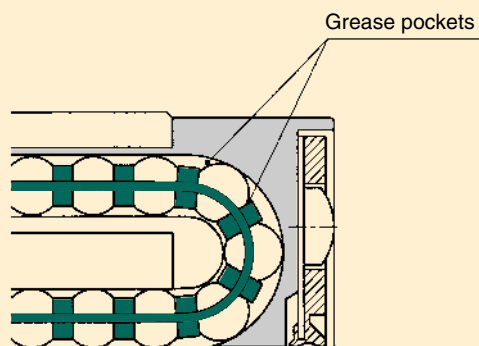

Figure 2

Long service life and long-term, maintenance-free operation

Because the Caged Ball™ design practically eliminates resistance between balls, grease retention is increased. This eliminates most friction-related problems and provides maintenance-free service for many years to come.

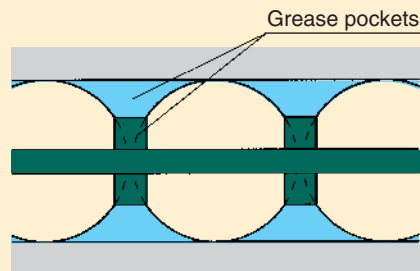

Figure 3

Excellent high-speed operation

Because the Caged Ball™ design reduces ball-to-ball friction, surface pressure and heat generation are reduced by about half, thus increasing operating speed.

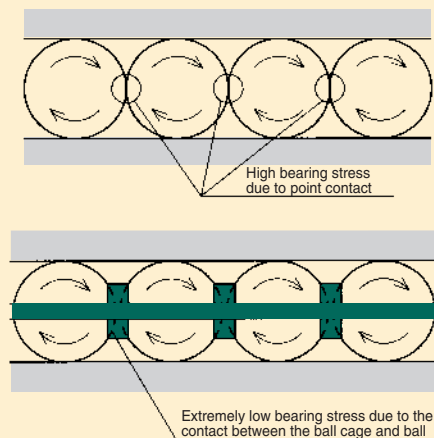

Figure 4

Super smooth movement

The bearing moves smoothly with only minimal variation in resistance since the balls are spaced uniformly as the bearing moves around.



Since the effect of the ball cages eliminates friction between adjacent balls while also enhancing the retention of grease, the basic

Model no.	Basic dynamic load ratings C kN
SHW17CAM	7.65
SHW21CA	8.24
SHW27CA	16.0
SHW35CA	35.5
SHW50CA	70.2

Model no.	Basic dynamic load ratings C kN
HRW17CA(M)	4.31
HRW21CA(M)	6.18
HRW27CA(M)	11.5
HRW35CA(M)	27.2
HRW50CA	50.2

Comparison of Basic Dynamic Load Ratings between Caged Ball™ LM Guide Model SHW and Uncaged LM Guide Model HRW

■ Noise level data

The ball circulating components in SHW-type bearings are molded inside the block. This eliminates metallic noise caused by balls contacting the block. The use of Caged Ball™ technology also prevents contact between the balls themselves, allowing the bearing to operate quietly even at high speeds. This same technology also eliminates friction between the balls, reducing heat generation and providing superb performance in high-speed operation.

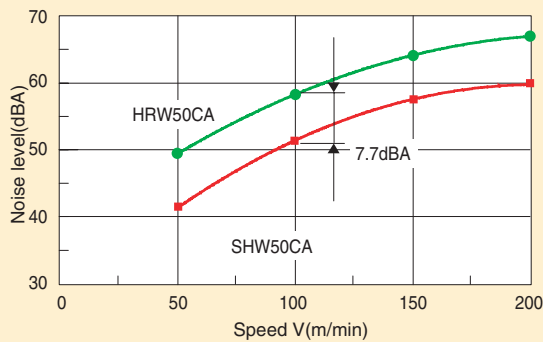

Figure 5 Comparison of noise levels in the SHW50CA and HRW50CA

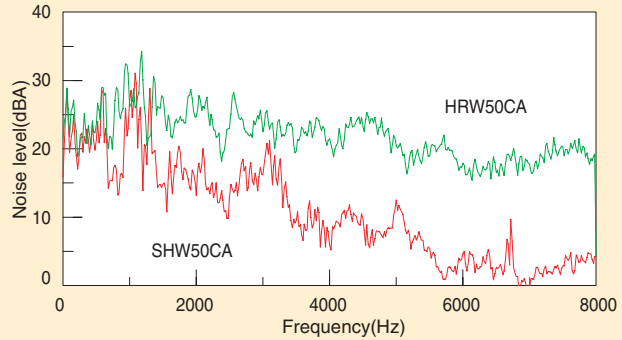

Figure 6 Comparison of noise levels in the SHW50CA and HRW50CA (speed: 50 m/min)

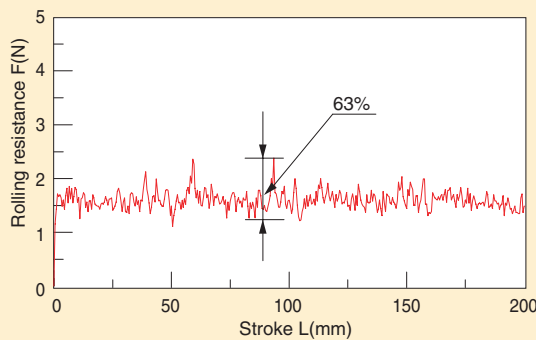

Figure 7 Results of the measurement of rolling resistance variation in an HRW50CA (feeding speed: 10 mm/sec)

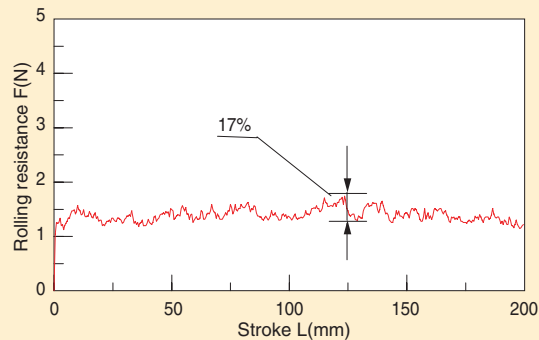

Figure 8 Results of the measurement of rolling resistance variation in an SHW50CA (feeding speed: 10 mm/sec)

■ Dust generation data

Because SHW-type bearings use the Caged Ball™ technology, the lubricating oil is retained in the bearing and the construction generates only minimal dust dispersion, providing excellent low dust-generation properties.

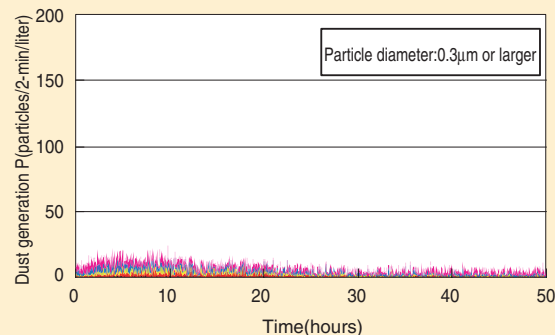

Figure 9 Results of dust generation measurement (using THK AFF grease) for an SHW21CA

SHW Features

Ultra-wide and low center of gravity

The SHW-type LM guide design conforms to that of the HRW type and continues the HRW tradition of wide rails and a low center of gravity. This construction makes SHW-type LM guides the ideal choice for locations where space is very limited and rigidity under Mc moment load is required

4-way equal load rating

This type of LM guide can be used in a wide range of applications in any position because each row of balls is arranged at a 45° angle. Consequently, the same load rating is applied to the LM block in all four directions (radial, reverse radial and both lateral directions).

Self aligning capability

The self aligning capability of THK's unique circular arc groove design (face-to-face/DF) means that mounting misalignment can be eliminated, even when a preload is applied, and allows high-precision, smooth linear movement.

Low dust generation

The Caged Ball™ technology construction used in SHW-type bearings provides extremely low levels of dust generation due to ability to retain lubricant.

Types and Features

SHW-CA

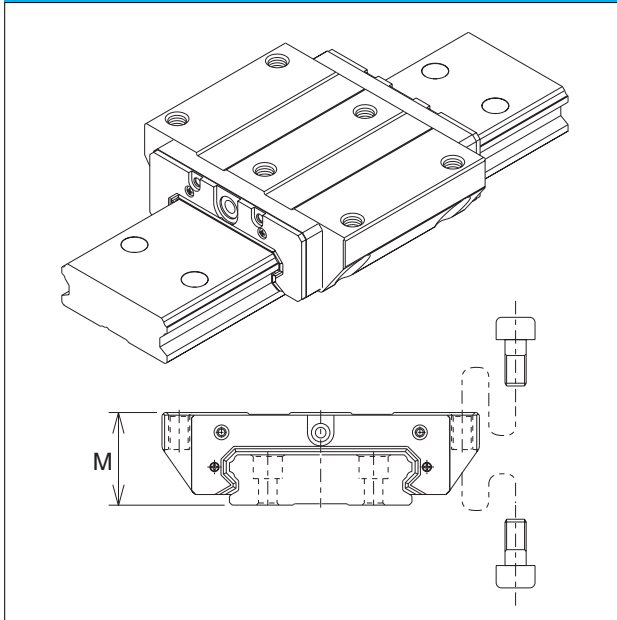

The SHW-CA type features a wide construction and a low center of gravity and can bear load in all 4 directions. The LM block installation holes are tapped and then counterbored from the underside of the flange, allowing the LM block to be mounted from either above or below (fixed at 4 points).

SHW-CR/HR

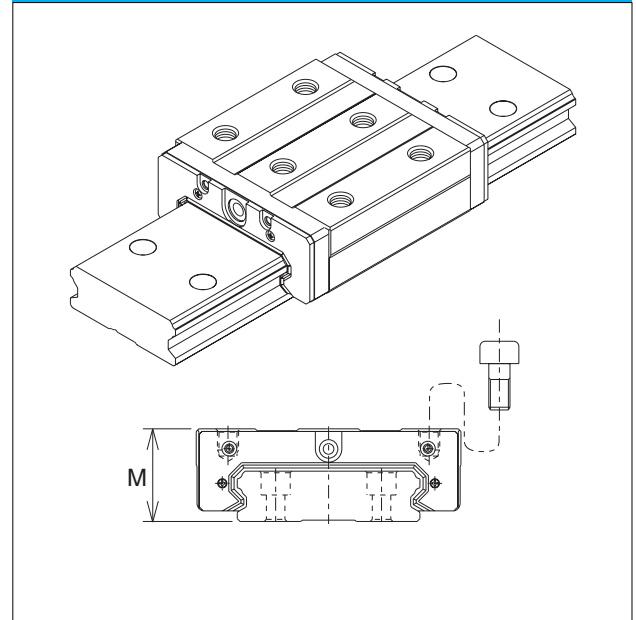

The SHW-CR type is a compact design that features a wide construction and low center of gravity, and can bear loads in all four directions. The LM block is installed using the holes tapped in the upper side. The SHW 12 includes the heavy-load SHW-HR type with an increased rated load capacity. This type features the same cross-sectional profile as the SHW-CR, but with an increased number of balls.

Options

Linear motion systems are subject to the entry of foreign matter, dust and moisture, which can lead to abnormal wear, damage to the rolling surfaces and balls, and breakage of circulating components. These will in turn shorten the service life of the system.

Accordingly, where the entry of foreign matter, dust, etc. is likely, you must implement effective countermeasures as appropriate for the operating environment. THK provides a wide range of options for SHW-type LM guides, as outlined below. Select the options best suited to your needs.

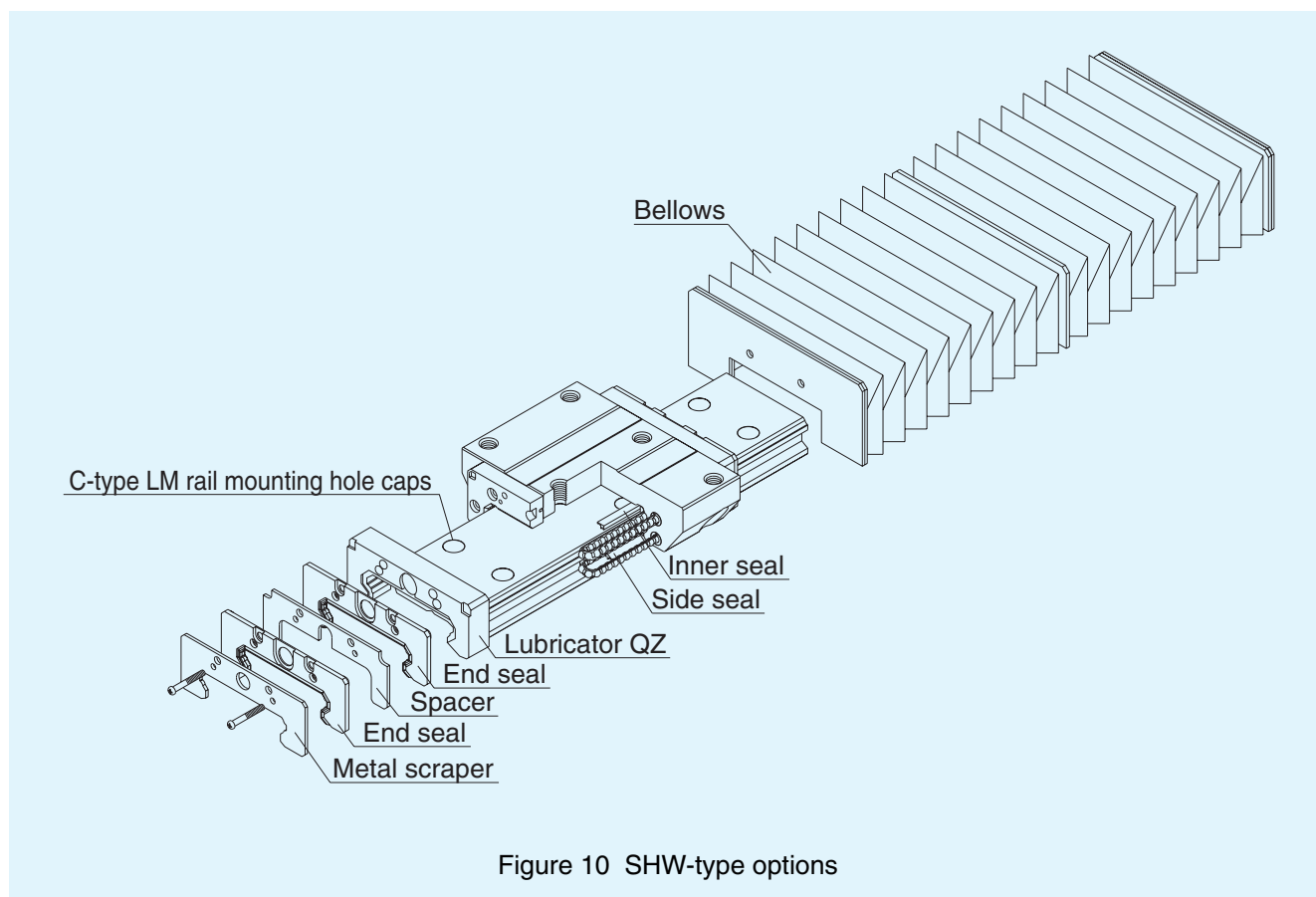
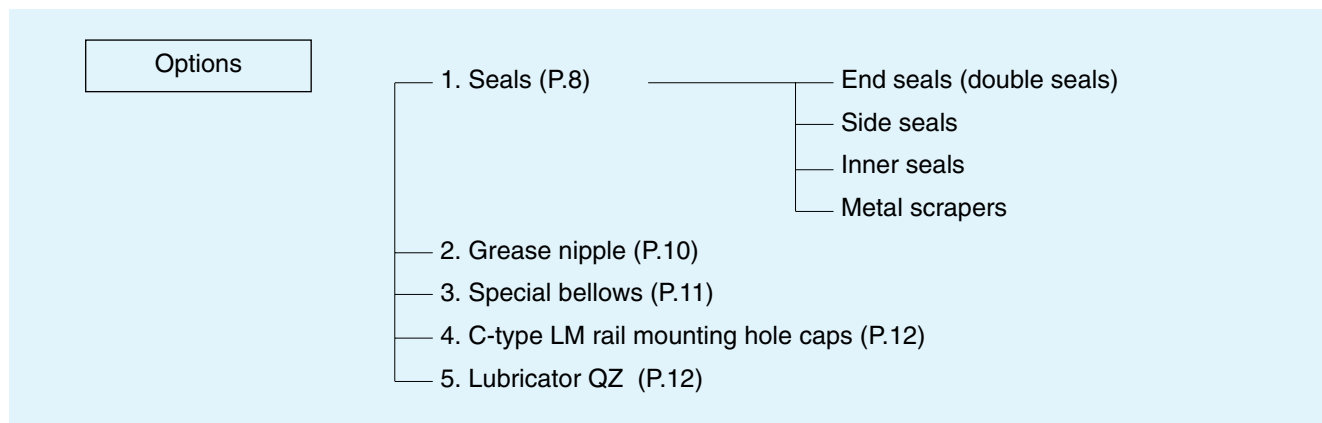
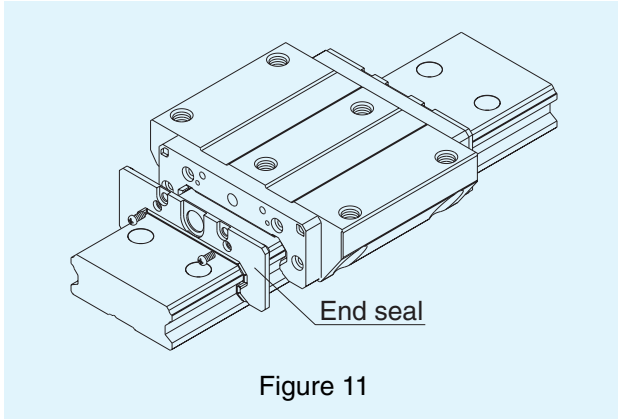

Figure 10 SHW-type options

1. Seals

End seals

End seals are fitted to both ends of an LM block to prevent foreign matter and moisture adhering to the LM rail top and sides from entering the LM block. End seals are also effective as a way of preventing leakage of the lubricant inside the LM block.



Double seals

Double seals provide still more effective sealing by using a double layer of end seals.

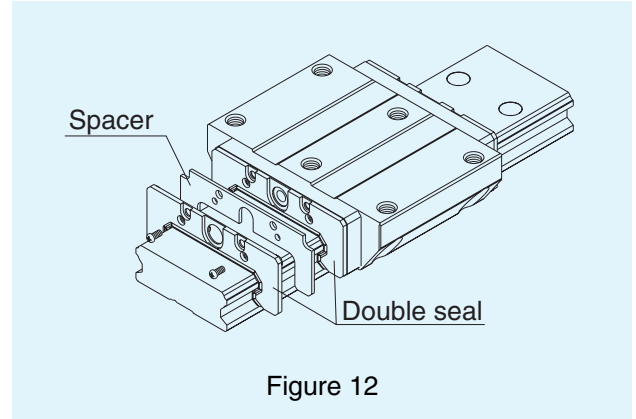

Side seals

Side seals prevent foreign matter from entering from the underside of the LM block and are also effective in preventing lubricant from leaking from the bottom of the block.

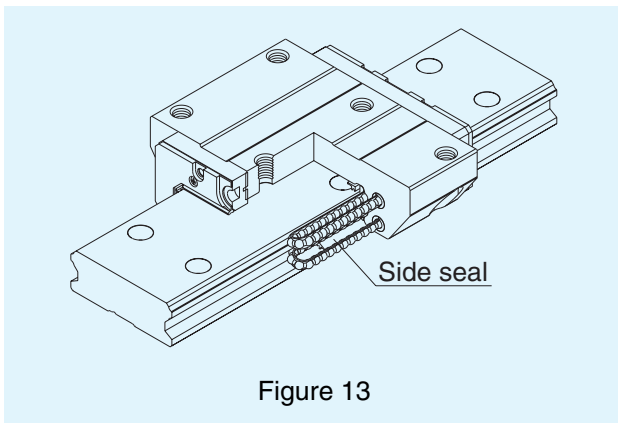

Inner seals

When very small particles of foreign matter or dust that were not kept out by the end seal enter the block, the inner seal prevents the particles from reaching the ball rolling surfaces.

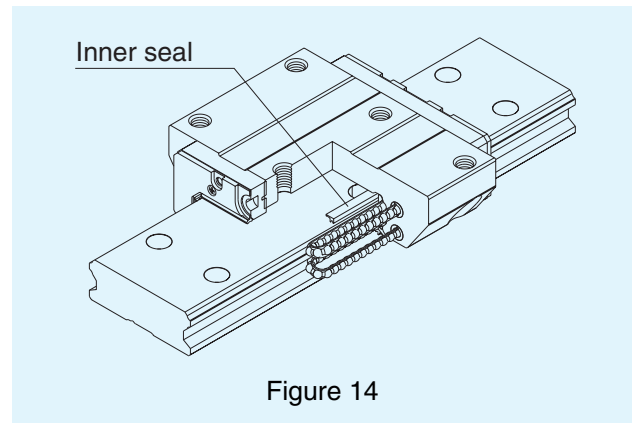

Metal scrapers (non-contact)

Metal scrapers are an effective means of removing relatively large particles of foreign matter such as chips, spatter and dust from the LM rail.

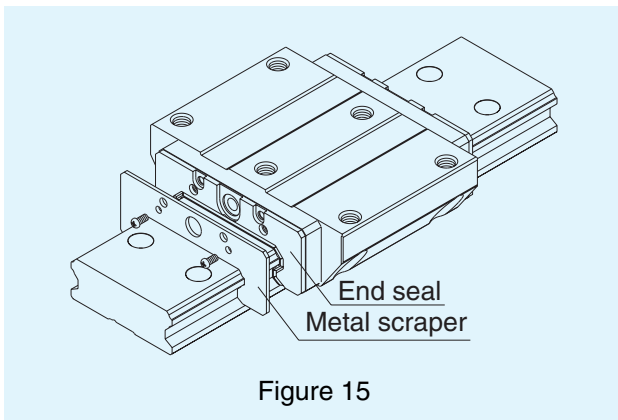

Codes for contamination protection parts

To obtain a dust control part, please specify the part number using the corresponding code in Table 1. Note that attaching an optional part will change the overall block length. Please contact  for details.

Table 1 Codes for contamination protection parts

Code	Contamination protection part
UU	With end seals (both ends)
SS	With end seals, side seals and inner seals *
ZZ	With end seals, side seals, inner seals and metal scrapers
DD	With double seals, side seals and inner seals
KK	With double seals, side seals, inner seals and metal scrapers

Note) SHW 12, 14, and 17 do not include inner seals (*).

2. Grease nipple (Lubrication hole)

Because the standard specifications do not include a grease nipple (Lubrication hole), you should select either the Lubricator QZ option* or Contact scraper LaCS option* when the guide is to be used in particularly harsh environments. If the guide still fails to run sufficiently smoothly with these options installed, select the grease nipple (Lubrication hole) option.

Note that installing the grease nipple changes the total length of the block.

(See Table 2 for information on models that support grease nipples and the dimensions.)

Note 1) The machining to install a grease nipple cannot be performed on a standard specification model.

Note 2) Contact  for more information on the Lubricator QZ and Contact scraper LaCS options.

Table 2 Grease nipple (Lubrication hole) dimensions

Model No.	Additional length with grease nipple E	Compatible models
SHW 12	—	ø2.2 drill hole
SHW 14	—	ø2.2 drill hole
SHW 17	3.5	PB107
SHW 21	4.4	PB1021B
SHW 27	10.8	B-M6F
SHW 35	10.2	B-M6F
SHW 50	14.9	B-PT1/8

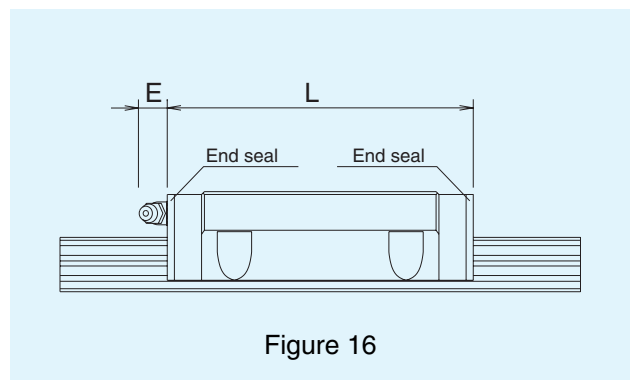

Figure 16

Note) See the dimensions tables for the length of dimension L.

3. Special JSHW-type bellows for the SHW type

Table 3 shows the dimensions of the special JSHW bellows for SHW-type LM guides. Specify the model numbers used below when ordering.

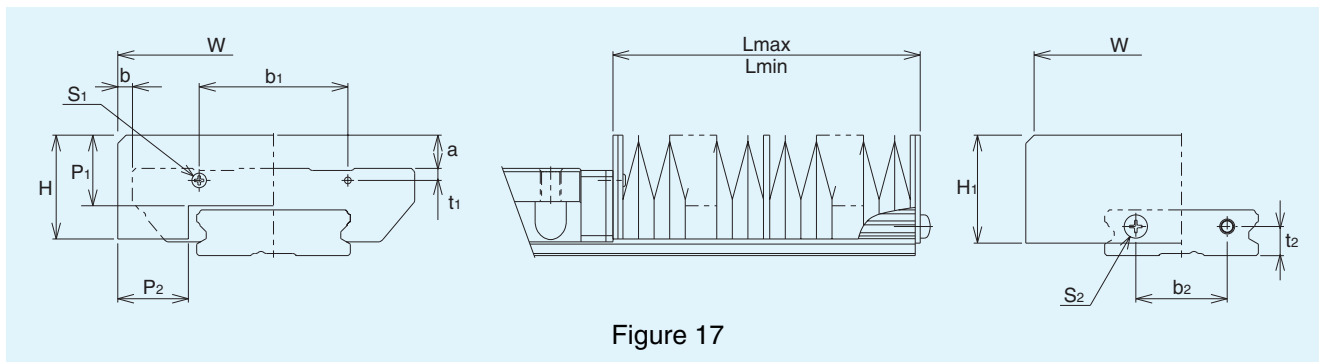

Figure 17

Table 3 JSHW type dimensions

Unit : mm

Model number	Main dimensions									Applicable model no.
	W	H	H ₁	P ₁	P ₂	b ₁	t ₁	b ₂	t ₂	
JSHW 17	68	22	23	15	15.4	39	2.6	18	6	SHW 17
JSHW 21	75	25	26	17	17	35.8	2.9	22	7	SHW 21
JSHW 27	85	33.5	33.5	20	20	25	3.5	20	10	SHW 27
JSHW 35	120	35	35	20	20	75	7.5	40	13	SHW 35
JSHW 50	164	42	42	20	20	89.4	14	50	16	SHW 50

Model number	Dimensions					A [$\frac{L_{MAX}}{L_{MIN}}$]
	Fixing bolts		a	b		
	*S ₁	S ₂		CA type	CR type	
JSHW 17	M2X4L	M3X0.5X6L	8	4	9	5
JSHW 21	M2X5L	M3X6L	8	3.5	10.5	6
JSHW 27	M2.6X6L	M3X6L	10	2.5	11.5	7
JSHW 35	M3X8L	M3X6L	6	0	10	7
JSHW 50	M4X12L	M4X8L	—	1	17	7

Note) Use self-tapping screws for bolts marked with an asterisk (*).

Model number coding

JSHW21 - 60/360

Bellows dimensions [$\frac{\text{Folded length}}{\text{Extended length}}$]

Model number

4. C cap for LM rail mounting holes

If dust or foreign matter enters an LM rail mounting hole on the LM guide, the contamination could also find its way into the inside of the block. This can be prevented by covering the mounting holes with the special caps provided and then ensuring that the caps are flush with the upper surface of the LM rail.

The C-type cap for LM rail mounting holes is made from a special synthetic resin that has excellent oil-proofing and wear-resistance properties, providing a high level of durability. Special caps for hexagon socket head (Allen) set screw types M4 to M16 are kept in stock as standard parts and can be ordered by specifying the model number listed in the table.

To insert a special cap into an LM rail mounting hole, lay a flat metal drift over the cap, as shown in Figure 18, and then gently tap the drift until the cap is flush with the top of the LM rail.

Table 4 Main dimensions of the special caps

Unit: mm

Model No.	C cap No.	Applicable bolt	Dimensions	
			D	H
SHW 12	C4	M4	7.8	1
SHW 14	C4	M4	7.8	1
SHW 17	C4	M4	7.8	1
SHW 21	C4	M4	7.8	1
SHW 27	C4	M4	7.8	1
SHW 35	C6	M6	11.4	2.7
SHW 50	C8	M8	14.4	3.7

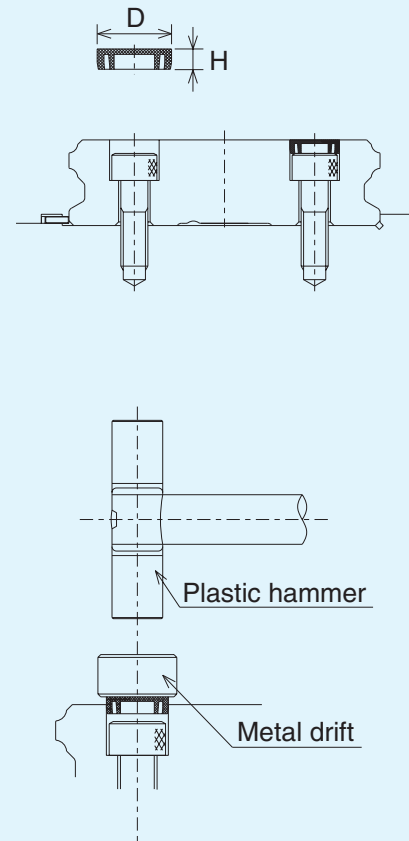

Figure 18

5. Lubricator QZ

THK has developed a lubricator QZ with a built-in fiber net of high oil content (absorbent) to eliminate the need for maintenance of the LM guide lubrication for a long term.

• A substantial extension of maintenance intervals

Normal grease lubrication is accompanied by loss of a very small amount of oil in traveling. Installation of the lubricator QZ makes up for lost oil and allows a substantial extension of maintenance intervals.

• Environment friendly lubrication system

The lubricator QZ uses a high density fiber net to supply a proper amount of oil to appropriate positions. This is an environment friendly lubrication system eliminating waste of oil.

• Setting of oil to meet application requirements

The lubricator QZ allows you to set the oil to be sealed in conformity to application requirements of the LM guide. SRS has the lubricator QZ available for you as a standard option. For further information, see THK Catalog No.230.

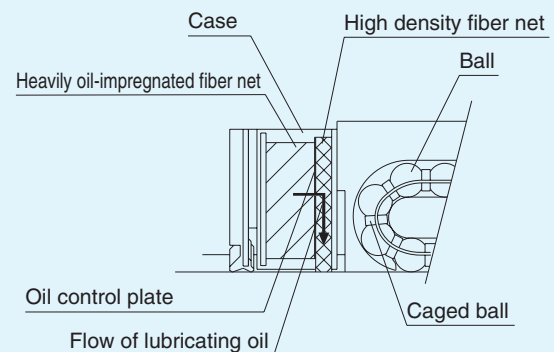

Figure 19

Load ratings and service life

THK SHW-type LM guides can support loads in the radial, reverse radial and lateral directions. The basic load ratings listed in the dimensions tables show the load ratings in the radial direction.

Calculating the service life

Use the following equation to calculate the service life of a THK SHW-type LM guide.

$$L = \left(\frac{f_t \cdot f_c}{f_w} \cdot \frac{C}{P_c} \right)^3 \cdot 50$$

- L** : Rated service life (km)
("Nominal service life" (L) refers to the average total distance traveled by 90% of a group of identical linear motion systems under identical conditions, without developing flaking.)
- C** : Basic dynamic load rating (N)
(The "basic dynamic load rating" (C) refers to the load of a group of identical linear motion systems under identical conditions (including direction and magnitude) such that the nominal service life (L) of the systems is 50 km (L = 50 km).)
- P_c** : Design load (N)
- f_t** : Temperature coefficient
(See general catalog)
- f_c** : Contact coefficient
(See general catalog)
- f_w** : Load factor
(See general catalog)

Given a rated service life (L) as calculated using the above equation and assuming that the stroke length and reciprocation rate are constant, the length of the service life can be calculated using the following

$$L_h = \frac{L \times 10^6}{2 \times l_s \times n_1 \times 60}$$

- L_h** : Length of service life (hours)
- l_s** : Stroke length (mm)
- n₁** : Number of reciprocating motions per minute (min⁻¹)

Load ratings and permissible moment in each direction

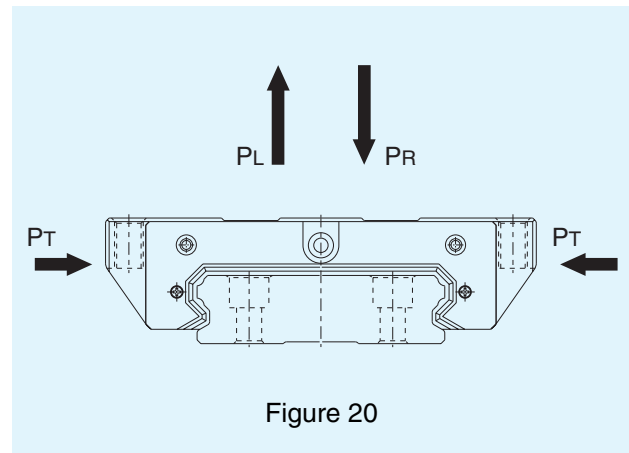

Load ratings

THK SHW-type LM guides can support loads in the radial, reverse radial and lateral directions. The basic load ratings in the four directions (radial, reverse radial and lateral) are equal and their values are listed in the dimensions tables.

Equivalent load

When an SHW-type LM block is subjected to simultaneous loading from each of the 4 directions, the equivalent load can be calculated using the following equation.

$$P_E = P_R (P_L) + P_T$$

- P_E** : Equivalent load (N)
- Radial
 - Reverse radial
 - Lateral

P_R : Radial load (N)

P_L : Reverse radial load (N)

P_T : Lateral load (N)

Permissible moment load

One SHW-type LM block can bear moment load in all directions. M_A , M_B and M_C in Table 5 indicate the respective permissible moment loads in each direction for one LM block and for 2 LM blocks in tandem (excluding M_C).

Table 5 Permissible static moment load for an SHW-type block

(Unit: kN·m)

Direction Model	M_A		M_B		M_C
	1 block	2 blocks in tandem	1 block	2 blocks in tandem	1 block
SHW 12CA/CR	0.023	0.14	0.023	0.14	0.038
SHW 12HR	0.052	0.28	0.052	0.28	0.058
SHW 14	0.046	0.28	0.046	0.28	0.084
SHW 17	0.058	0.34	0.058	0.34	0.160
SHW 21	0.08	0.45	0.08	0.45	0.22
SHW 27	0.19	1.01	0.19	1.01	0.42
SHW 35	0.55	3.12	0.55	3.12	1.65
SHW 50	1.32	7.52	1.32	7.52	3.78

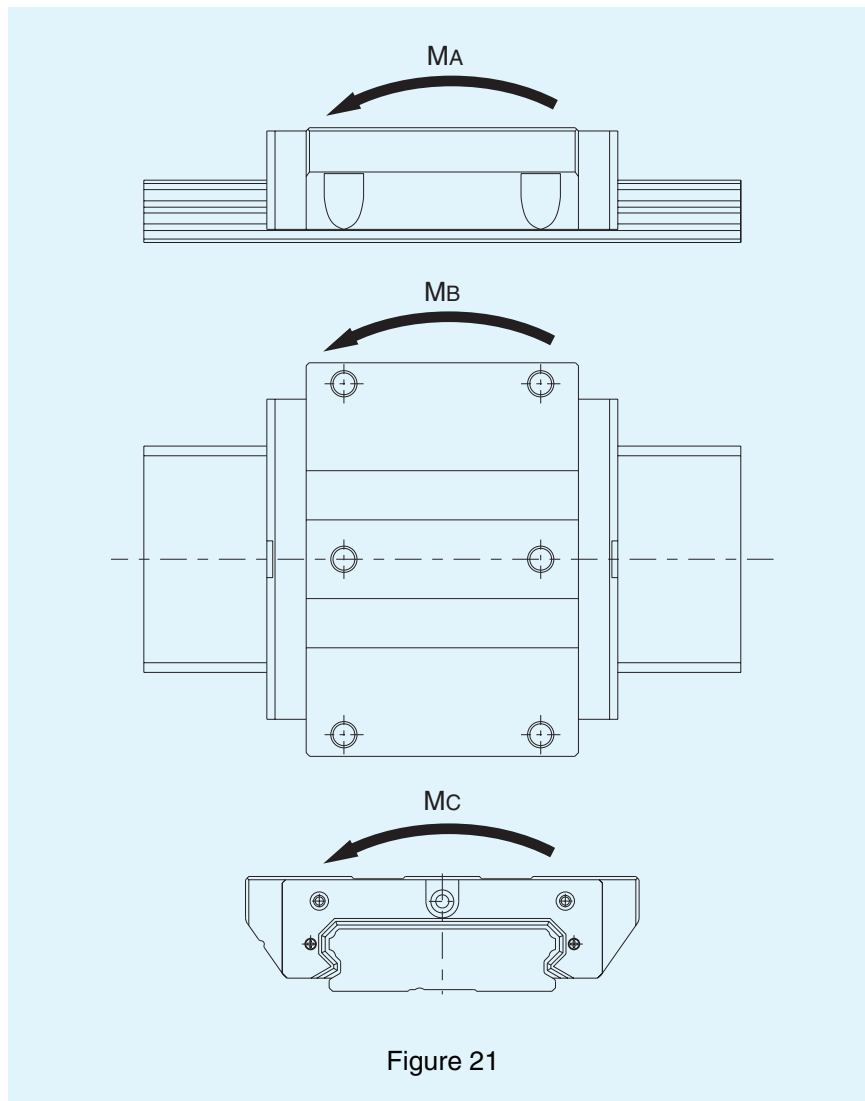

Notes on Use

Installation surface shoulder heights and bottom corners

Table 6 lists the recommended shoulder heights for installing the LM block and LM rail. To prevent corner bevelling or interference between the LM block and LM rail, the corner of the installation surface should have some clearance or should be machined to a radius equal to or less than r in Table 6.

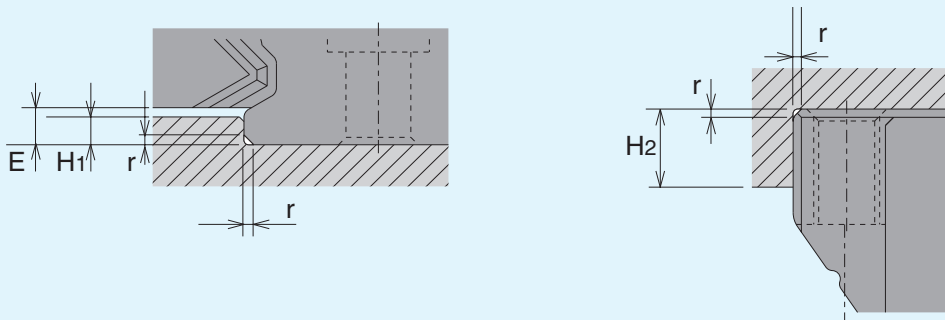

Figure 22

Table 6 Installation surface shoulder height and corner radius

Unit : mm

Model No.	Bottom corner radius r (max.)	LM rail shoulder height H_1	LM block shoulder height H_2	E
SHW 12	0.5	1.5	4	2
SHW 14	0.5	1.5	5	2
SHW 17	0.4	2	4	2.5
SHW 21	0.4	2.5	5	3
SHW 27	0.4	2.5	5	3
SHW 35	0.8	3.5	5	4
SHW 50	0.8	3	6	3.4

Seal resistance

Table 7 shows the maximum values for seal resistance in 1 LM block when lubricant is applied to an SHW-type LM guide with seals (UU-type and SS-type).

Table 7 Seal resistance

Unit : N

Model No.	Resistance	
	UU	SS
SHW 12CA/CR	1.0	1.4
SHW 12HR	1.0	1.8
SHW 14	1.2	1.8
SHW 17	1.4	2.2
SHW 21	4.9	6.9
SHW 27	4.9	8.9
SHW 35	9.8	15.8
SHW 50	14.7	22.7

Precision Standards

Table 8 shows the precision standards for the SHW-type LM guides. The precision is shown in terms of the parallelism and the height and width tolerances. When 2 or more LM blocks are installed on 1 rail or when 2 or more rails are installed in the same plane, the precision is defined in terms of the discrepancies in the required height and width between the rails.

Running parallelism

See the General Catalog.

Difference in height M

See the General Catalog.

Difference in width W2

See the General Catalog.

The precision for SHW-type LM guides is classified into Normal, High, Precision, Super-precision and Ultra-precision grades, as shown in Table 8.

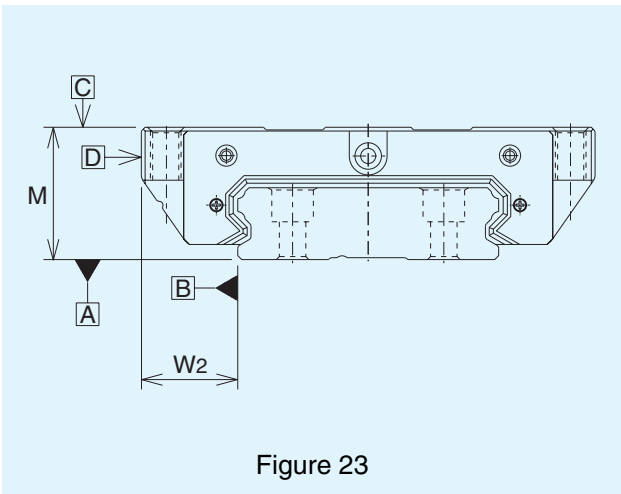

Figure 23

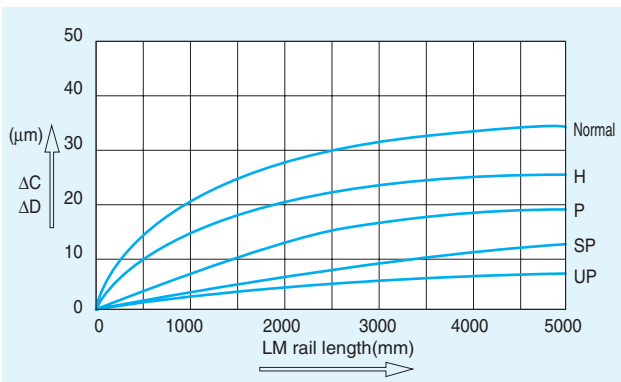

Figure 24 LM rail length and the running parallelism

Table 8 Precision standards

Unit : mm

Model No.	Precision standard	Normal	High	Precision	Super-precision	Ultra-precision	
SHW 12	Item	Unmarked	H	P	SP	UP	
	Tolerance of height M	±0.08	±0.04	±0.02	±0.01	—	
	Difference in height M	0.015	0.007	0.005	0.003	—	
	SHW 14	Tolerance of width W2	±0.05	±0.025	±0.015	±0.010	—
		Difference in width W2	0.02	0.01	0.007	0.005	—
	Running parallelism of flat [C] with respect to flat [A]	ΔC (see Fig. 24)					
Running parallelism of flat [D] with respect to flat [B]	ΔD (see Fig. 24)						
SHW 17	Item	Unmarked	H	P	SP	UP	
	Tolerance of height M	±0.1	±0.03	⁰ / _{-0.03}	⁰ / _{-0.015}	⁰ / _{-0.008}	
	Difference in height M	0.02	0.01	0.006	0.004	0.003	
	Tolerance of width W2	±0.1	±0.03	⁰ / _{-0.03}	⁰ / _{-0.015}	⁰ / _{-0.008}	
	Difference in width W2	0.02	0.01	0.006	0.004	0.003	
	Running parallelism of flat [C] with respect to flat [A]	ΔC (see Fig. 24)					
Running parallelism of flat [D] with respect to flat [B]	ΔD (see Fig. 24)						
SHW 21	Item	Unmarked	H	P	SP	UP	
	Tolerance of height M	±0.1	±0.03	⁰ / _{-0.03}	⁰ / _{-0.015}	⁰ / _{-0.008}	
	Difference in height M	0.02	0.01	0.006	0.004	0.003	
	Tolerance of width W2	±0.1	±0.03	⁰ / _{-0.03}	⁰ / _{-0.015}	⁰ / _{-0.008}	
	Difference in width W2	0.02	0.01	0.006	0.004	0.003	
	Running parallelism of flat [C] with respect to flat [A]	ΔC (see Fig. 24)					
Running parallelism of flat [D] with respect to flat [B]	ΔD (see Fig. 24)						
SHW 27	Item	Unmarked	H	P	SP	UP	
	Tolerance of height M	±0.1	±0.04	⁰ / _{-0.04}	⁰ / _{-0.02}	⁰ / _{-0.01}	
	Difference in height M	0.02	0.015	0.007	0.005	0.003	
	Tolerance of width W2	±0.1	±0.04	⁰ / _{-0.04}	⁰ / _{-0.02}	⁰ / _{-0.01}	
	Difference in width W2	0.03	0.015	0.007	0.005	0.003	
	Running parallelism of flat [C] with respect to flat [A]	ΔC (see Fig. 24)					
Running parallelism of flat [D] with respect to flat [B]	ΔD (see Fig. 24)						
SHW 35	Item	Unmarked	H	P	SP	UP	
	Tolerance of height M	±0.1	±0.04	⁰ / _{-0.04}	⁰ / _{-0.02}	⁰ / _{-0.01}	
	Difference in height M	0.02	0.015	0.007	0.005	0.003	
	Tolerance of width W2	±0.1	±0.04	⁰ / _{-0.04}	⁰ / _{-0.02}	⁰ / _{-0.01}	
	Difference in width W2	0.03	0.015	0.007	0.005	0.003	
	Running parallelism of flat [C] with respect to flat [A]	ΔC (see Fig. 24)					
Running parallelism of flat [D] with respect to flat [B]	ΔD (see Fig. 24)						
SHW 50	Item	Unmarked	H	P	SP	UP	
	Tolerance of height M	±0.1	±0.05	⁰ / _{-0.05}	⁰ / _{-0.03}	⁰ / _{-0.02}	
	Difference in height M	0.03	0.015	0.007	0.005	0.003	
	Tolerance of width W2	±0.1	±0.05	⁰ / _{-0.05}	⁰ / _{-0.03}	⁰ / _{-0.02}	
	Difference in width W2	0.03	0.02	0.01	0.007	0.005	
	Running parallelism of flat [C] with respect to flat [A]	ΔC (see Fig. 24)					
Running parallelism of flat [D] with respect to flat [B]	ΔD (see Fig. 24)						

Radial clearance

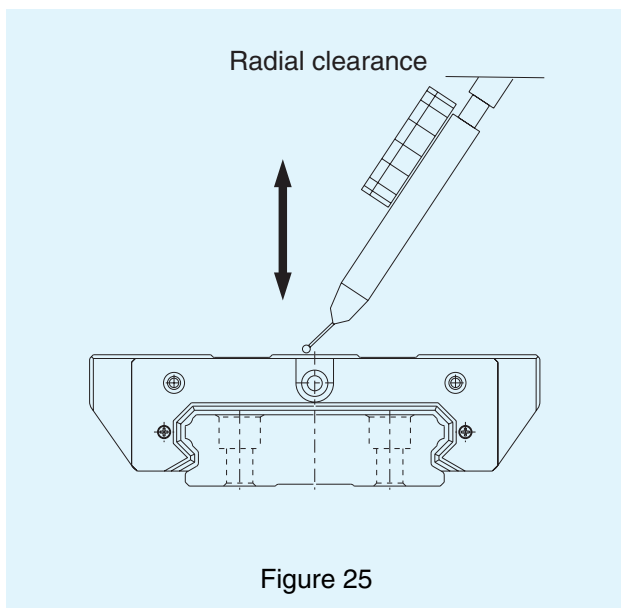

Figure 25

Table 9 shows the radial clearances for SHW-type LM guides.

Table 9 Radial clearances for SHW-type LM guides

Unit : μm

Model No.	Symbol	Normal	Light preload	Medium preload
	Unmarked	C1	C0	
SHW 12		-1.5 ~ 0	-4 ~ -1	—
SHW 14		-2 ~ 0	-5 ~ -1	—
SHW 17		-3 ~ 0	-7 ~ -3	—
SHW 21		-4 ~ +2	-8 ~ -4	—
SHW 27		-5 ~ +2	-11 ~ -5	—
SHW 35		-8 ~ +4	-18 ~ -8	-28 ~ -18
SHW 50		-10 ~ +5	-24 ~ -10	-38 ~ -24

Note) No symbol is required for normal clearance. Add the corresponding symbols to the model number for clearances C1 or C0. (See the explanation of model number coding below.)

Model number coding

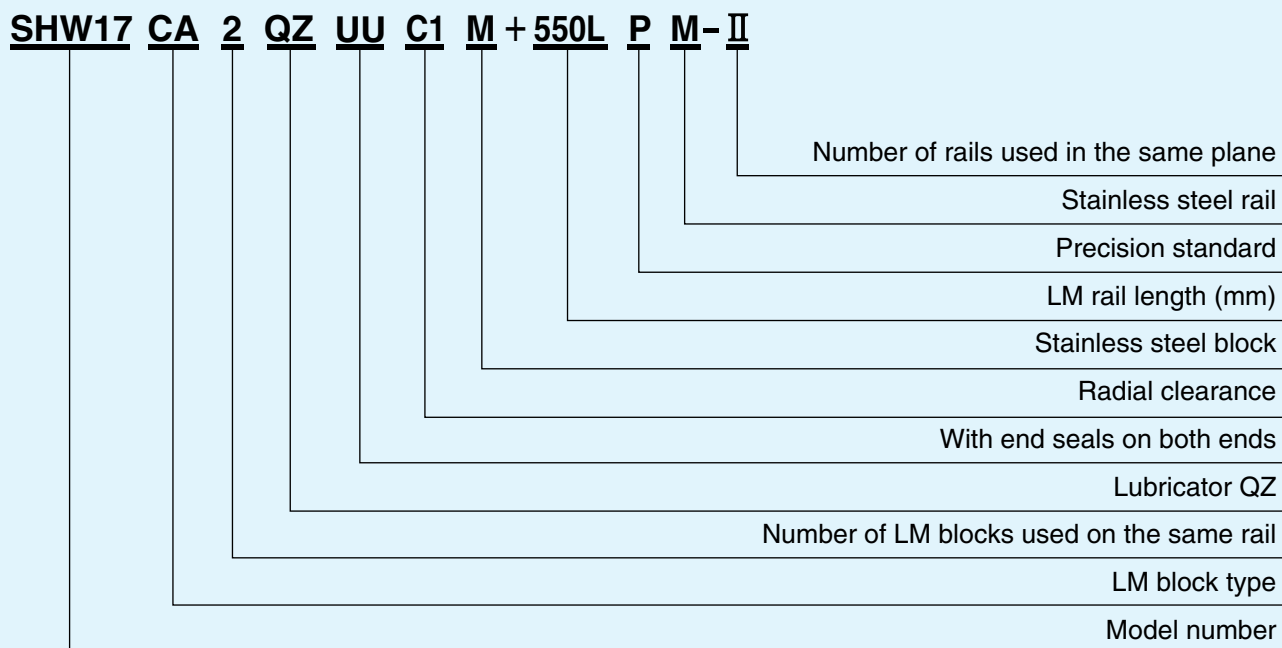

- Notes) · This model number applies to 1 set on 1 rail unit. (At least 2 sets are required when used on 2 parallel rails.)
 · Specify "With grease nipple" when ordering if a grease nipple is required. For the SHW 12 and 14, specify "With lubrication hole".

Standard and maximum LM rail lengths

Table 10 shows the standard and maximum LM rail lengths for the SHW-type LM guides. If the rail length exceeds the maximum length, the rail will be manufactured in 2 or more sections. If a special length is required, the G dimension given in the table should be used. If the G dimension is too long, the ends of the rail tend to become unstable after installation, which adversely affects precision.

When 2 or more rail sections are to be connected, you must specify the total length required so that THK can manufacture the sections using simultaneous machining to ensure that the joins are smooth.

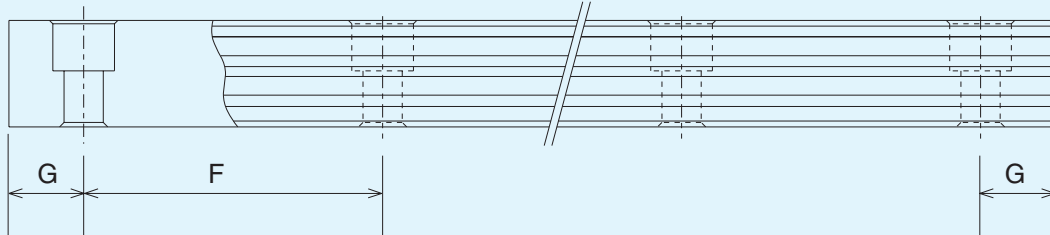

Figure 26

Table 10 Standard and maximum LM rail lengths for SHW-type LM rails

Unit: mm

Model No.	SHW 12	SHW 14	SHW 17	SHW 21	SHW 27	SHW 35	SHW 50
LM rail standard length (L ₀)	70	70	110	130	160	280	280
	110	110	190	230	280	440	440
	150	150	310	380	340	760	760
	190	190	470	480	460	1000	1000
	230	230	550	580	640	1240	1240
	270	270		780	820	1560	1640
	310	310					2040
	390	390					
	470	470					
			550				
		670					
Standard pitch F	40	40	40	50	60	80	80
G	15	15	15	15	20	20	20
Maximum length	1000	1430	1800	1900	3000	3000	3000

Notes) · The maximum length differs depending on the precision grade. Contact THK for details.

- If a length exceeding the maximum length is required and the rail cannot be divided into sections, contact THK.
- SHW 12, 14, and 17 are constructed of stainless steel.

Flange Type

Type SHW-CA Type SHW-CAM

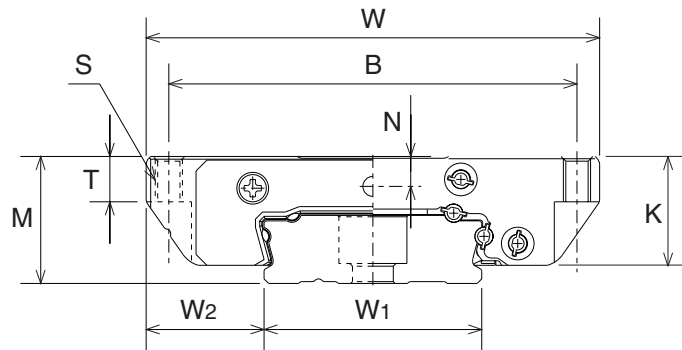

SHW 12CAM, SHW 14CAM

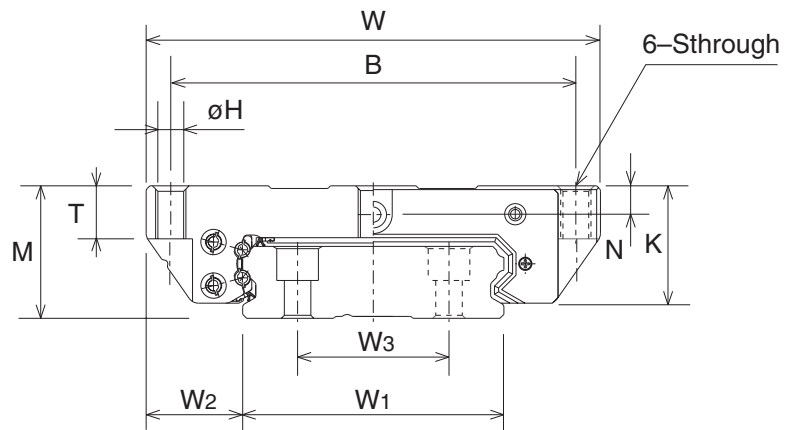

SHW 17~50 CA

Model No.	External dimensions			Block dimensions							Nipple position
	Height M	Width W	Length L	B	C	S	H	L ₁	T	K	
SHW 12CAM	12	40	37	35	9	M 3	2.5	27	4	10	2.8
SHW 14CAM	14	50	45.5	45	12	M 3	2.5	34	5	12	3.3
SHW 17CAM	17	60	51	53	26	M 4	3.3	38	6	14.5	4
SHW 21CA	21	68	59	60	29	M 5	4.4	43.6	8	17.7	5
SHW 27CA	27	80	73	70	40	M 6	5.3	56.6	10	23.5	6
SHW 35CA	35	120	107	107	60	M 8	6.8	83	14	31	7.6
SHW 50CA	50	162	141	144	80	M10	8.6	107	18	46	14

- Notes)
- Because machining is required to install a grease nipple, specify "with grease nipple" when ordering.
 - See P.14 for the static permissible moment loads M_A , M_B and M_C .
 - See P.17 for a breakdown of the model number coding.
 - See P.18 for information on standard LM rail lengths.
 - An "M" in a model number indicates that the corresponding LM blocks, rails, and balls are made of stainless steel and are therefore corrosion- and environment-resistant.

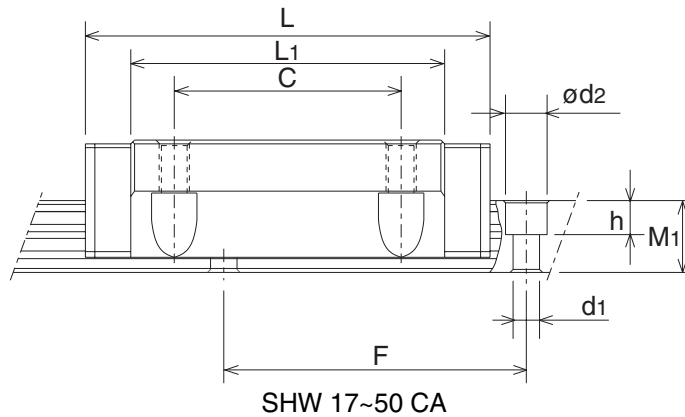
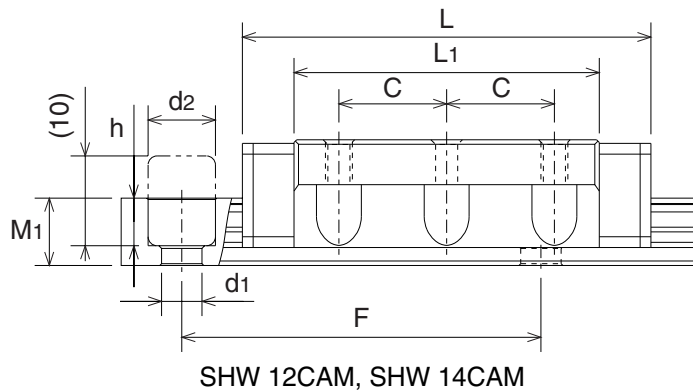

Unit : mm

Rail dimensions					Basic load rating		Mass		
Width W ₁	W ₂	W ₃	Height M ₁	Pitch F	d ₁ ×d ₂ ×h	C kN	C ₀ kN	LM block kg	LM rail kg/m
18	11	—	6.6	40	4.5×7.5×5.3	4.31	5.66	0.05	0.80
24	13	—	7.5	40	4.5×7.5×5.3	7.05	8.98	0.10	1.23
33	13.5	18	8.6	40	4.5×7.5×5.3	7.65	10.18	0.15	1.90
37	15.5	22	11	50	4.5×7.5×5.3	8.24	12.8	0.24	2.9
42	19	24	15	60	4.5×7.5×5.3	16.0	22.7	0.47	4.5
69	25.5	40	19	80	7×11×9	35.5	49.2	1.4	9.6
90	36	60	24	80	9×14×12	70.2	91.4	3.7	15

Note) To prevent the entry of foreign matter, the grease nipple installation hole is not drilled through.
To use this hole, contact THK.

Compact Type

Type SHW-CR
Type SHW-CRM
Type SHW-HRM

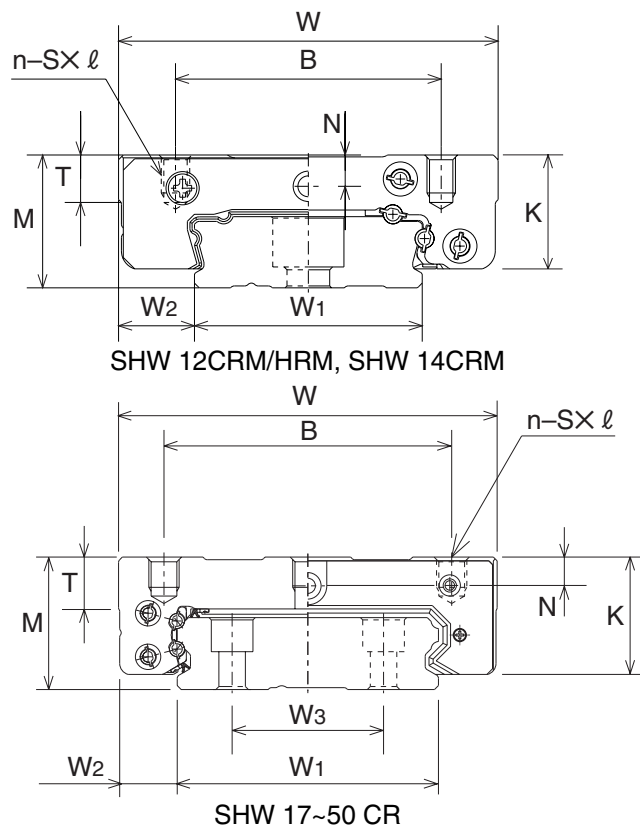

Model No.	External dimensions			Block dimensions							Nipple position N
	Height M	Width W	Length L	B	C	SXℓ	n	L ₁	T	K	
SHW 12CRM	12	30	37	21	12	M3X3.5	4	27	4	10	2.8
SHW 12HRM	12	30	50.4	21	24	M3X3.5	4	40.4	4	10	2.8
SHW 14CRM	14	40	45.5	28	15	M3X4	4	34	5	12	3.3
SHW 17CRM	17	50	51	29	15	M4X5	4	38	6	14.5	4
SHW 21CR	21	54	59	31	19	M5X6	4	43.6	8	17.7	5
SHW 27CR	27	62	73	46	32	M6X6	6	56.6	10	23.5	6
SHW 35CR	35	100	107	76	50	M8X8	6	83	14	31	7.6
SHW 50CR	50	130	141	100	65	M10X15	6	107	18	46	14

- Notes)
- Because machining is required to install a grease nipple, specify "with grease nipple" when ordering.
 - See P.14 for the static permissible moment loads M_A, M_B and M_C.
 - See P.17 for a breakdown of the model number coding.
 - See P.18 for information on standard LM rail lengths.
 - An "M" in a model number indicates that the corresponding LM blocks, rails, and balls are made of stainless steel and are therefore corrosion- and environment-resistant.

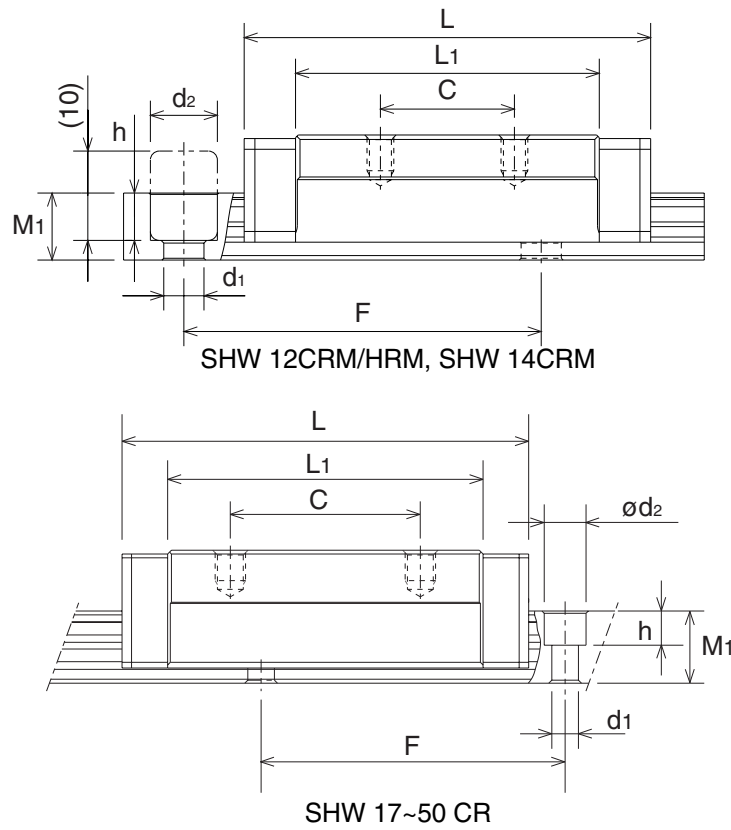

Unit : mm

Rail dimensions						Basic load rating		Mass	
Width W ₁	W ₂	W ₃	Height M ₁	Pitch F	d ₁ ×d ₂ ×h	C kN	C ₀ kN	LM block kg	LM rail kg/m
18	6	—	6.6	40	4.5×7.5×5.3	4.31	5.66	0.04	0.80
18	6	—	6.6	40	4.5×7.5×5.3	5.56	8.68	0.06	0.80
24	8	—	7.5	40	4.5×7.5×5.3	7.05	8.98	0.08	1.23
33	8.5	18	8.6	40	4.5×7.5×5.3	7.65	10.18	0.13	1.90
37	8.5	22	11	50	4.5×7.5×5.3	8.24	12.8	0.19	2.9
42	10	24	15	60	4.5×7.5×5.3	16.0	22.7	0.36	4.5
69	15.5	40	19	80	7×11×9	35.5	49.2	1.2	9.6
90	20	60	24	80	9×14×12	70.2	91.4	3.0	15

Note) To prevent the entry of foreign matter, the grease nipple installation hole is not drilled through.
To use this hole, contact THK.

THK Extra-wide equal load-rating LM Guide with Caged Ball™ Technology

SHW

⚠ Notes on use

*Precautions when handling the LM block

The LM block contains precision-molded resin components. Take great care when handling the block since dropping or striking the block could damage it.

*Using the grease nipple socket

When the grease nipple socket in the LM block is to be used, the nipple is installed by ㄱㄱㄱ. (To prevent the entry of foreign matter, the hole is not drilled through.) Note also that the nipple socket is designed specifically for grease nipple installation and should not be used for any other purpose as this could damage the socket.

*Reinstalling the LM block

Take great care when reinstalling the block once it has been removed from the LM rail.

*Coolant

If this product is to be used in an environment where coolant may get into the LM block, contact ㄱㄱㄱ, as some types of coolant can impair the functioning of the LM block.

*Operating temperature range

Do not use the LM block in temperatures above 80°C as it uses a special resin.

*Lubrication

In some cases, it may not be possible to use ordinary grease when this product is used in special environments such as an area subject to extremes of temperature or vibration, a clean room, or in a vacuum. If this product is to be used in such an environment, contact ㄱㄱㄱ.

※All rights reserved.

※Specifications are subject to change without notice.

THK THK CO., LTD.

HEAD OFFICE 3-11-6, NISHI-GOTANDA, SHINAGAWA-KU, TOKYO 141-8503 JAPAN
INTERNATIONAL SALES DEPARTMENT PHONE:(03)5434-0351 FAX:(03)5434-0353

U. S. A.

CHICAGO
PHONE:(847)310-1111 FAX:(847)310-1182
NEW JERSEY
PHONE:(201)529-1950 FAX:(201)529-1962
LOS ANGELES
PHONE:(714)891-6752 FAX:(714)894-9315
SAN FRANCISCO
PHONE:(925)455-8948 FAX:(925)455-8965
ATLANTA
PHONE:(770)840-7990 FAX:(770)840-7897
DETROIT
PHONE:(248)858-9330 FAX:(248)858-9455
BOSTON
PHONE:(781)575-1151 FAX:(781)575-9295
INDIANAPOLIS
PHONE:(317)243-3496 FAX:(317)243-3499
MINNEAPOLIS
PHONE:(612)953-4442 FAX:(612)953-4441
CANADA (MISSISSAUGA,ONT)
PHONE:(905)712-2922 FAX:(905)712-2925
BRASIL (SÃO PAULO)
PHONE:(011)3924-0911 FAX:(011)3924-0900

GERMANY

DÜSSELDORF
PHONE:(02102)74250 FAX:(02102)7425299
STUTTGART
PHONE:(07141)2757-0 FAX:(07141)2757-90
U.K. (MILTON KEYNES)
PHONE:(01908)222159 FAX:(01908)222161
FRANCE (LYON)
PHONE:(0437)49.14.00 FAX:(0437)49.14.01
ITALY (MILAN)
PHONE:(039)2842079 FAX:(039)2842527
SWEDEN (STOCKHOLM)
PHONE:(08)4457630 FAX:(08)4457639
AUSTRIA (LINZ)
PHONE:(07229)51400 FAX:(07229)51400-79
SPAIN (BARCELONA)
PHONE:(093)652-5740 FAX:(093)652-5746
PGM BALLSCREWS LIMITED (COVENTRY)
PHONE:(02476)841900 FAX:(02476)611032
PGM BALLSCREWS IRELAND LIMITED (DUBLIN)
PHONE:(01)4628101 FAX:(01)4629080

TAIWAN

TAIPEI
PHONE:(02)2585-8554 FAX:(02)2585-8495
TAICHUNG
PHONE:(04)2359-1505 FAX:(04)2359-1506
CHINA
BEIJING
PHONE:(10)6590-3557 FAX:(10)6590-3557
HONG KONG
PHONE:2376-1091, 2376-1252 FAX:2376-0749
MALAYSIA (KUALA LUMPUR)
PHONE:(03)9287-1137 FAX:(03)9287-8071
INDIA (BANGALORE)
PHONE:(080)330-1524 FAX:(080)330-1524
KOREA (SEOUL)
PHONE:(02)3463-0351 FAX:(02)3017-0351

